

DEVELOPMENT REGULATIONS
FOR THE
TOWN OF PARMA
MONROE COUNTY, NEW YORK



ADOPTED BY:

THE TOWN OF PARMA PLANNING BOARD
AUGUST 19, 2013

APPROVED BY:

THE TOWN OF PARMA TOWN BOARD
OCTOBER 1, 2013

PREPARED BY:

CHATFIELD ENGINEERS, P.C.
2800 DEWEY AVENUE
ROCHESTER, NY 14616
(585) 227-6040

www.chatfieldengineers.com



**DEVELOPMENT REGULATIONS
FOR THE
TOWN OF PARMA
MONROE COUNTY, NEW YORK**

TABLE OF CONTENTS

<u>DESCRIPTION</u>	<u>PAGE</u>
INTRODUCTION	I-1
SECTION 1. GENERAL REQUIREMENTS	
1.1. DEFINITIONS, VARIANCES, AMMENDMENTS AND VALIDITY	1-1
1.1.1 Definitions	1-1
1.1.2 Variances	1-4
1.1.3 Amendments	1-4
1.1.4 Validity	1-4
1.2. Requirements for Subdivision of Land.	1-4
1.3. Summary of Procedures for Subdivision of Land.	1-4
1.3.1. Applications and Review	1-4
1.4. Letter of Credit.	1-5
1.5. Easements.	1-6
1.6. Certificates of Occupancy and Completion.	1-6
1.7. Requirements for Approval for Dedication.	1-7
1.7.1. Completion of Construction	1-7
1.7.2. Grading	1-7
1.7.3. Monuments and Property Corner Markers	1-7
1.7.4. Street and Traffic Signs	1-7
1.7.5. Roads and Streets	1-7
1.7.6. Easements and Special Use Districts	1-7
1.7.7. Record Drawings	1-7
1.7.8. Maintenance Bonds	1-8
1.7.9. Final Release of Funds	1-9
1.7.10 Checklist for Dedication	1-9
1.8. Submission Requirements for Review.	1-10
1.8.1. Concept Plans	1-10
1.8.2. Preliminary Engineering Report	1-11
1.8.3. Preliminary Drainage Report	1-11
1.8.4. Preliminary Plans	1-12
1.8.5. Final Engineering Report	1-13
1.8.6. Final Drainage Report	1-13
1.8.7. Final Plans	1-13
1.8.8. Standard Plan Notes	1-14
SECTION 2. DESIGN STANDARDS	
2.1. General.	2-1
2.2. References to Other Specifications.	2-1
2.3. Responsibility for Design.	2-1
2.4. Water Distribution System.	2-1
2.4.1. General	2-1
2.4.2. Public Water Systems	2-1
2.5. Sanitary Sewer Systems.	2-2
2.5.1. General	2-2
2.5.2. Public Sanitary Sewer Systems	2-2
2.5.3. Pumping Stations and Forcemains	2-2
2.6. Storm Drainage Systems.	2-3

2.6.1.	General	2-3
2.6.2.	Design Standards	2-4
2.6.3.	Hydrologic Design	2-4
2.6.4.	Storm Sewers and Channels	2-4
2.6.5.	Open Channels	2-4
2.6.6.	Details of Hydraulic Structures	2-4
2.6.7.	Surcharging of Drainage Facilities	2-5
2.6.8.	Building and Lot Storm Drainage	2-5
2.6.9.	Storm Water Management Facilities	2-6
2.7.	Erosion and Sediment Control.	2-6
2.7.1.	General	2-6
2.7.2.	Steep Slopes	2-7
2.7.3.	Flood Hazard Control	2-7
2.8.	Roads and Streets.	2-8
2.8.1.	General	2-8
2.8.2.	Design Standards	2-8
2.8.3.	Horizontal Design Requirements	2-9
2.8.4.	Vertical Design Requirements	2-10
2.8.5.	Intersection Design Requirements	2-10
2.8.6.	Grading and Roadside Swales	2-11
2.8.7.	Sidewalks	2-11
2.8.8.	Street Trees	2-11
2.8.9.	Street Names	2-12
2.8.10.	Monuments	2-12
2.8.11.	Property Corner Markers	2-12
2.8.12.	Road Dedication Requirements	2-12
2.8.13.	Driveway Design Requirements	2-13
2.9.	Street Lighting.	2-14
2.9.1.	General	2-14
2.9.2.	Design Standards	2-14
2.10	Off Street Parking	2-14
2.10.1	General	2-14
2.11	Lighting for Parking Lots and Pedestrian Walkways	2-15
2.12	Landscaping and Buffers	2.15

SECTION 3. CONSTRUCTION STANDARDS		<u>PAGE</u>
3.1.	General.	3-1
3.1.1.	Preliminary Matters	3-1
3.1.2.	Pre-Construction Meeting	3-1
3.1.3.	Inspection	3-1
3.1.4.	Responsibility for Construction	3-1
3.1.5.	Protection of Existing Utilities and Structures	3-1
3.1.6.	Permits and Traffic Control	3-2
3.1.7.	Shop Drawings and Manufacturer's Information	3-2
3.1.8.	Noise Control	3-2
3.1.9.	Weather Conditions	3-2
3.1.10.	Connection To and Operation of Existing Facilities	3-3
3.1.11.	Record Drawings	3-3
3.1.12	Site Safety	3-3
3.1.13	Checklist for Notice to Proceed	3-4
3.2.	Site Preparation.	3-4
3.2.1.	General	3-4
3.2.2.	Clearing and Grubbing	3-4
3.2.3.	Layout of Work	3-4
3.2.4.	Topsoil Removal and Stockpiling	3-5
3.2.5.	Erosion and Siltation Control	3-5
3.2.6.	Temporary Access	3-5

3.3.	Grading, Excavation and Related Work.	3-5
3.3.1.	Grading	3-5
3.3.2.	Trench Excavation	3-5
3.3.3.	Separation of Backfill Material	3-6
3.3.4.	Dewatering	3-6
3.3.5.	Maintenance of Banks	3-6
3.3.6.	Pipe Bedding	3-6
3.3.7.	Cradle Materials	3-7
3.3.8.	Special Requirements at Structures	3-7
3.3.9.	Special Requirements for Building Sewers	3-8
3.4.	Backfill and Embankments.	3-8
3.4.1.	General	3-8
3.4.2.	Materials	3-8
3.4.3.	Embankments and Fills	3-9
3.4.4.	Trench Backfill	3-9
3.4.5.	Compaction	3-10
3.4.6.	Density Tests	3-11
3.4.7.	Site Maintenance and Cleanup	3-11
3.5.	Water Distribution System.	3-11
3.5.1.	Materials for Water Mains and Services	3-11
3.5.2.	Installation of Water Mains and Appurtenances	3-11
3.5.3.	Installation of Services	3-11
3.5.4.	Preparation for Use	3-11
3.6.	Sanitary Sewer System.	3-11
3.6.1.	Materials	3-11
3.6.2.	Installation of Main Sewers and Building Sewers	3-15
3.6.3.	Installation of Manholes	3-16
3.6.4.	Preparation of Sewer System for Use	3-17
3.7.	Storm Drainage System.	3-21
3.7.1.	Materials for Storm Drainage System	3-21
3.7.2.	Installation of Storm Sewers	3-23
3.7.3.	Installation of Manholes	3-24
3.7.4.	Installation of Inlets	3-25
3.7.5.	Preparation for Use	3-25
3.8.	Roadways and Streets.	3-26
3.8.1.	Materials	3-26
3.8.2.	Preparation of Subgrade	3-27
3.8.3.	Foundation Course	3-27
3.8.4.	Pavement Construction	3-28
3.8.5.	Concrete Gutters	3-29
3.8.6.	Curbs	3-30
3.8.7.	Concrete Sidewalks	3-31
3.8.8.	Driveways	3-32
3.8.9.	Street and Traffic Signs	3-32
3.8.10.	Monuments	3-32
3.8.11.	Property Corner Markers	3-32
3.9.	Street Lighting.	3-32
3.9.1.	General	3-32
3.9.2.	Materials	3-33
3.9.3.	Installation of Street Lighting	3-34

SECTION 4. STANDARD DETAILS

See Standard Detail Index

INTRODUCTION

These Standards have been prepared to provide guidelines for, and control over, the development of land within the Town of Parma.

The intent is to assure proper design and construction of facilities, which will be dedicated to the Town, and to assure that development is compatible with the long-range development plans of the Town.

It is the intent of these Standards to conform with the Code of the Town of Parma or general control of development by the Town Board and Planning Board, and it is intended to supplement such policies by providing the technical details necessary to carry out general policy by Parma Town Code.

These Standards are divided into four Sections.

Section 1 - General Requirements

The intent is to provide a guide that will assist in expeditious approval of development plans and completed works, which are to be dedicated to the Town.

Section 2 - Design Standards

The Design Standards provides a guide for Developers' Engineers in the preparation of plans and other information for the development of land.

Section 3 - Construction Standards

The Construction Standards provides the construction specifications. Developers and their Engineers are responsible that their Contractors follow these Specifications in constructing dedicated facilities.

Section 4 - Standard Details

The Standard Details provide detail drawings that supplement the Construction Standards.

SECTION 1. GENERAL REQUIREMENTS

1.1. DEFINITIONS, VARIANCES, AMMENDMENTS AND VALIDITY

1.1.1 DEFINITIONS

Unless otherwise expressly stated, the following terms shall, for the purpose of these regulations, have the meaning indicated.

Words in the singular include the plural, and words in the plural include the singular. The word "person" includes a corporation, unincorporated association and a partnership as well as an individual. The word "building" includes "structure" and shall be construed as if followed by the words "or part thereof". The word "street" includes "road", "highway", and "lane"; and "watercourse" includes "drain", "ditch", and "stream". The words "shall" or "will" are mandatory; the word "may" is permissive.

ALLEY (or Service Drive) - A strip of land over which there is a right-of-way serving as a means of access to one or more private properties.

BLOCK - An area bounded by streets.

BUILDER - An individual, partnership or corporation who obtains a building permit for construction of a structure or structures on lots within the proposed development.

CONCEPT CONFERENCE AND REVIEW STAGE - A plan submitted to the Planning Board showing existing features of the land and a schematic layout of the proposed lots and streets within and adjacent to a subdivision in accordance with applicable sections of these regulations. The Concept Conference and Review Stage is required so as to assist the Developer with the proper planning of the project, however confers no legal rights to the Developer/Owner.

CONTRACTOR - The construction firm hired by a developer, including subcontractors, to construct the required improvements of the project. The Contractor is responsible to perform the work in conformance with the approved plans and Town Development Regulations, and subject to the review of Town officials.

PEDESTRIAN WALK - A right-of-way, municipally or privately owned, which cuts across a block or land to furnish access for pedestrians to adjacent streets or properties.

CUL-DE-SAC - A residential street with one end open for public vehicles and pedestrian access and the other end terminating in a vehicular turnaround.

DEVELOPER - Subdivider and/or an individual, partnership or corporation holding title to a parcel of land to be developed or subdivided. Commitments and/or requirements for development are solely between the Town of Parma and the Developer or their assignees.

DEVELOPER'S ENGINEER - Designated by the Developer as his Consulting Engineer or Architect, registered in the State of New York who prepares the required plans and acts on the Developer's behalf.

DOUBLE FRONTAGE LOT - A lot having at least two sides fronting on separate streets that do not intersect while adjoining the lot.

EASEMENT - A right granted to use certain land for a special purpose not inconsistent with the general property rights of the owner.

FINAL PLAT - A drawing prepared in a manner prescribed by local regulation, that shows a proposed subdivision, containing in such additional detail as shall be provided by local regulation all information required to be shown on a preliminary plat and the modifications, if any, required by the planning board at the time of approval of the preliminary plat if such preliminary plat has been so approved.

FINAL PLAT (CONDITIONAL APPROVAL) - Approval by a planning board of a final plat subject to conditions set forth by the planning board in a resolution conditionally approving such plat. Such conditional approval does not qualify a final plat for recording nor authorize issuance of any building permits prior to the signing of the plat by a duly authorized officer of the planning board and recording of the plat in the office of the county clerk or register as herein provided.

FINAL PLAT APPROVAL - means the signing of a plat in final form by a duly authorized officer of a planning board pursuant to a planning board resolution granting final approval to the plat or after conditions specified in a resolution granting conditional approval of the plat are completed. Such final approval qualifies the plat for recording in the office of the county clerk or register in the county in which such plat is located.

GRADING PLAN - A plan showing all present and proposed grades for storm water drainage and disposal.

HALF STREET - One half of a street right-of-way and paving, usually with its centerline located on a property line.

IMPROVEMENTS - Those physical additions and changes to the land that may be necessary to produce usable and desirable lots. These may include but are not necessarily limited to grading, paving, curbing, fire hydrants, water mains, sanitary sewers, storm sewers, and lighting standards and monuments.

LOT - A parcel of land intended for transfer of ownership or building development, that is presently occupied or capable of being occupied by one principal building or use and by those buildings or uses accessory to the principal building or use.

OWNER - The individual, corporation or partnership who owns the parcel of land to which the Developer's improvements will serve. Can also be the Developer or subsequent purchaser of the property.

PLANNING BOARD - The word Board or the words Planning Board or Town Planning Board shall mean the Town of Parma Planning Board.

PRELIMINARY PLAT - means a drawing prepared in a manner prescribed by these regulations showing the layout of a proposed subdivision including, but not restricted to, road and lot layout and approximate dimensions, key plan, topography and drainage, all proposed facilities unsized, including preliminary plans and profiles, at suitable scale and in such detail as these regulation may require.

PRELIMINARY PLAT APPROVAL - means the approval of the layout of a proposed subdivision as set forth in a preliminary plat but subject to the approval of the plat in final form in accordance with the provisions of this section.

PROJECT OBSERVER - An agent of the Town empowered to observe the progress of the project and the compliance of the construction with the specifications and/or approved plans. They shall have the power to halt construction should the Contractor and/or Developer not be performing the work in a satisfactory manner or in accordance with the approved plan of Town Development Regulations.

PUBLIC HEARING - A legal public hearing which is advertised in the Town's legal newspaper in accordance with Town Municipal Law. The public hearing shall allow interested parties to become informed and offer comments, concerns, etc.

RIGHT-OF-WAY - Land opened for use as a street, alley or pedestrian way.

STREET - A general term used to describe a right-of-way, municipally or privately owned, serving as a means of vehicular and pedestrian travel, furnishing space for sewers, public utilities, and shade trees. The streets are classified by function as follows:

1. Private Road - A private street or road shall be considered as one serving no more than three (3) lots and will not be dedicated to the Town.
2. Town Road - A residential street or a connecting street serving primarily developed neighborhoods with relatively low volumes of through traffic.
3. Town Connector or Collector - A street connecting district centers, serving large volumes of through traffic, preferably located outside or bounding the residential neighborhoods.

SUBDIVISION - means the division of any parcel of land into a number of lots, blocks or sites as specified in a local ordinance, law, rule or regulation, with or without streets or highways, for the purpose of sale, transfer of ownership, or development. The term "subdivision" may include any alteration of lot lines or dimensions of any lots or sites shown on a plat previously approved and filed in the office of the county clerk or register of the county in which such plat is located.

TOWN ATTORNEY - The legal representative of the Town responsible for review of documentation as required for districts, easements, letters of credit, dedication, surety or other legal matters.

TOWN BOARD - Elected officials responsible for acting on behalf of the residents of the Town of Parma for the betterment, protection and welfare of the community. When Town Board is designated, it will be stated as Town Board.

TOWN ENGINEER - The duly designated Engineer of the Town of Parma, or if there be no such designee, the Engineer assigned to the Town Planning Board. The Town Engineer shall be responsible to review the project plans, progress of construction, and make recommendations and/or require changes of the Developer to insure that the best interests of the Town shall be preserved in conformance with the standards herein established.

TOWN HIGHWAY SUPERINTENDENT - Person directly in charge of the department who shall assume the operation and maintenance of the portion of the development upon dedication to the Town of Parma.

WETLANDS - Wetlands may be defined, determined and regulated by the Town of Parma, New York State Department of Environmental Conservation, and the U.S. Army Corps of Engineers.

1.1.2 VARIANCES

The standards and requirements of these regulations may be modified by the Planning Board in the case of a plan and program for a new large scale complete community or a neighborhood unit, which in the judgment of the Planning Board provides adequate public spaces and improvements for the circulation, recreation, light, air, and service needs of the tract when fully developed and populated, and which will also provide such covenants to other legal provisions as will assure conformity to and achievement of the plan; provided that no such modification shall be granted which will have the effect of nullifying the intent and purpose of these regulations or any other pertinent rules, regulations or zoning ordinances of the Town of Parma.

In granting modifications to these regulations, the Planning Board may require such conditions as will, in its judgment, secure substantially the objectives of the standards or requirements so varied and modified.

1.1.3 AMENDMENTS

The rules and regulations as set forth above may be amended, altered or revised by the Planning Board from time to time, after public hearing held by Town board and subject to the subsequent approval of the Town Board. Notice of Public Hearing shall be published once in the official paper at least 10 but not more than 20 days before the day set for the hearing.

1.1.4 VALIDITY

Should any section or provision of these Rules and Regulations be in conflict with the Town Code of the Town of Parma, the Town Code shall take precedence.

Should any section or provision of these Rules and Regulations be declared by a court of competent jurisdiction to be invalid, such ruling shall not affect the validity of the rules and regulations as a whole, or any other part thereof.

1.2. REQUIREMENTS FOR SUBDIVISION OF LANDS AND SITE PLANS

The procedures for the approval of subdivisions and site plans are included in the Chapter 130 of the Town of Parma Code. Approval of site plans is required prior to the issuance of building permits, subject to the provisions and restrictions the Town Code and Section 274-a and 276 of New York State Town Law Article 16.

1.3. SUMMARY OF PROCEDURES FOR SITE PLANS

1.3.1. APPLICATIONS AND REVIEW.

The Developer shall file applications on forms provided by the Clerk to the Planning Board, pay any application fees and submit information required for each phase of the review process. All required forms and information

must be submitted to the Clerk of the Planning Board within the time specified in Chapter 130 of the Town of Parma Code.

1.4. IRREVOCABLE LETTER OF CREDIT

Upon receiving final approval of the particular subdivision section or other types of development for which the Planning Board or Building Inspector deems these procedures to be appropriate, the Developer's Licensed Professional Engineer shall submit a preliminary estimate of cost of improvements. This shall be itemized in detail and shall consist of the following major sections:

- WATER SUPPLY SYSTEM
- SANITARY SEWER SYSTEM
- STORM SEWER SYSTEM
- SITE WORK/GRADING
- ROAD/SIDEWALKS
- MISCELLANEOUS, EROSION CONTROL, STREET LIGHTS, STREET SIGNS

This shall be submitted to the Town Engineer together with a copy of the approved plan. The estimate shall include the following items:

CONSTRUCTION COSTS (outlined above)
CONTINGENCIES 10%
SURVEY MONUMENTS AND NECESSARY STAKE OUT
RECORD DRAWINGS
OWNER'S GUARANTEE 5%
TOWN OBSERVATION FOR DEDICATED FACILITIES (5% minimum)
LANDSCAPING (WHERE APPLICABLE)
DEDICATION OF ROAD - \$1,000 PAID TO THE TOWN
OTHER ITEMS AS REQUIRED BY TOWN

The Letter of Credit shall be written so as to comply with the terms and conditions specified by the Town. Unless otherwise required by the Town, recreation fees and engineering review fees are not to be included in the Letter of Credit and must be paid to the Town prior to the issuance of a building permit or prior to establishing a date for a public hearing where necessary. In such instances where the appropriate Town authority requires that the Letter of Credit include provision for engineering review fees and/or the cost of Town observation of improvements to be dedicated, the said Letter of Credit shall expressly direct the bank holding said letter to pay such engineering fees to the Town.

The Letter of Credit shall be constituted that, administratively and legally, the funds may be withdrawn by the Town upon certification by the Town Supervisor, employee, or agent responsible for accepting the construction for dedication that there is reasonable cause to utilize such funds; and after appropriate action by resolution by the Town Board authorizing the removal and use of such funds for such appropriate purpose.

The Letter of Credit amount shall include funds necessary for the costs incurred by the Town for observation, Town Engineer's advisory services during construction, and surveys and testing necessary to assure completeness and satisfactory quality of the work.

The observation items shall include sufficient allowance for Town observation of facilities and improvements to be dedicated. All engineering services related to the construction stage that have not been paid from the Letter of Credit, shall be charged directly to the Developer. The Town shall not issue a Certificate of Occupancy until such charges have been paid to the Town.

The Letter of Credit shall be so written to allow the Town to draw from the funds to perform any and all work if the Developer does not diligently, systematically, and expeditiously perform the work.

If the Developer fails to perform in accordance with the Town Standards and specifications or the site plan, then the Town shall give written notice of such failure, and the Developer shall have a reasonable time not-to-exceed fifteen (15) calendar days from receipt of such notices, authorizes the Town to perform and properly complete such items contained in such notice forthwith and to be reimbursed for the cost thereof under the Letter of Credit of the Developer to the Town in place and instead of the Developer, as if the funds under such Letter of Credit were advanced to the Developer. The Developer will provide for such authority in the Letter of Credit.

The Letter of Credit shall be issued by a bank, or a bonding or surety company, or by the Owner/Developer with security acceptable to the Town Board, and shall be approved by the Town Board and the Attorney for the Town as to form, sufficiency, and manner of execution.

The Letter of Credit is to be renewed yearly. The Town Clerk will make notice of renewal. That is, renewal is required one year from the date the letter is established, and each year thereafter that the project is active. Prior to each renewal date, the Town Engineer shall review the amounts quoted in the letter. An increase in the Letter of Credit dollar amount may be required before renewal is permitted, to reflect current construction costs. The Developer must take this into account at each yearly review period and shall submit, 30 days prior to expiration date, an estimate of remaining work to establish a new Letter of Credit amount.

1.5. EASEMENTS

The Developer shall provide permanent easements to the Town for dedicated facilities located outside dedicated Town street rights-of-way. Easements shall also be provided for drainage swales, channels and streams crossing private property.

Easements shall be prepared prior to the approval of the final subdivision plat. The Developer is responsible for preparation of easement descriptions and maps, transfer of the easements to the Town, and recording in the Monroe County Clerk's Office.

The Town reserves the right to require easements for anticipated future facilities and roads, where in the opinion of the Town such easements are necessary for planning future development of adjacent land.

1.6. CERTIFICATES OF OCCUPANCY AND COMPLETION

Certificates of Occupancy shall not be issued until the binder course is placed on all dedicated and private streets. Where sidewalks are part of

the improvements, the Certificate of Occupancy shall not be issued until sidewalks are constructed in the area affected by such certificate.

Certificate of Completion shall be issued only after completion and acceptance of dedicated utilities, grading, drainage systems and erosion control.

1.7. REQUIREMENTS FOR APPROVAL FOR DEDICATION

1.7.1. COMPLETION OF CONSTRUCTION.

Construction of all facilities to be dedicated shall be fully completed by the Developer, and inspected and found satisfactory by the Town.

1.7.2. GRADING.

Final grading and seeding shall be completed within the right-of-way and all excess excavated material shall be removed from the site.

1.7.3. MONUMENTS AND PROPERTY CORNER MARKERS.

Monuments shall be set in the required locations as shown on the final subdivision plat approved by the Planning Board, and shall be on the record drawings. All permanent corner markers shall be in place for each lot.

1.7.4. STREET AND TRAFFIC SIGNS.

All street and traffic signs shall be set in their designated locations.

1.7.5. ROADS AND STREETS.

Roads and streets offered for dedication shall be completed and shall stand over one winter season prior to acceptance by the Town. In addition, 75% of lots in the section to be dedicated shall be completed.

Any agreement to maintain a road or street prior to dedication shall be developed in conjunction with the Town Highway Superintendent, subject to review by the Attorney for the Town and approval of the Town Board.

1.7.6. EASEMENTS AND SPECIAL USE DISTRICTS.

All easements and special use districts (water, sewer, drainage, lighting sidewalk, etc.) shall be completed and filed in accordance with Section 190 of NYS Town Law.

1.7.7. RECORD DRAWINGS.

Record drawings of all dedicated facilities, private underground utilities, and all test results shall be submitted to the Town.

The Developer's design engineer shall prepare record drawings and submit the following prints and digital copies in a format acceptable to the Town:

- Town Building Department – one set prints and digital copy.
- Town Highway Department – one set of prints.
- Town Engineer – one set of prints and digital copy.

The following information shall be shown on the record drawings:

1. Location, sizes, elevations, lengths, slopes and invert and top elevations of all manholes, inlets, sanitary sewers and storm sewers.
2. Location and significant elevations of drainage swales, stormwater management facilities and other key surface elevations.
3. The size and location of all water mains, valves, curb stops and hydrants including ties from permanent structures.
4. Finished profiles and typical cross-sections of roads and streets.
5. Location of building sewer, storm lateral and water service curb box at the property line of each individual lot.
6. Any other significant information necessary for the operation or maintenance of the system.
7. Location of buildings and other permanent features.
8. All rights-of-way and easements.
9. Location of all survey monumentation.

1.7.8. MAINTENANCE BONDS.

The Developer shall warrant all work performed and material furnished against defect, failure, in adequacy, or breakage for a period of two-years from the date of final acceptance of the work by the Town Board. Two-year Maintenance Bonds shall be submitted to the Town for all improvements to be offered to the Town for dedication. The Bond shall be for a term of two-year from the acceptance for dedication.

Maintenance Bonds shall be written by a surety licensed to do business in New York State and they shall be in the amount of ten percent (10%) of the final construction cost. No maintenance Bond shall be less than \$5,000. Alternatively, the Developer may provide maintenance fees in the form of cash or letter of credit to the benefit of the Town.

In the event of such defect, failure, inadequacy, or breakage during the Maintenance period, the Developer shall make the necessary repairs or replacements within two-days of notice given by the Town or their Engineer or within a mutually agreed upon schedule.

Should the Developer fail, neglect, or refuse to so comply with the specified time, the Town shall make the necessary repairs or replacements and deduct all costs therefore from monies or securities being held by the Town to ensure compliance during the warranty period. The warranty period shall commence no earlier than June 1 or later than October 1 and expire two years thereafter.

1.7.9. RELEASE OF FUNDS.

The Town Board will authorize periodic releases of funds in the Letter of Credit, as individual components of the development are completed and upon recommendation from the Town Engineer. The Town shall not construe partial releases as acceptance of the work.

The Town Board will authorize final release of funds retained in the Letter of Credit upon recommendation from the Town Engineer, after receipt of a two-year Maintenance Bond and certified record drawings.

If the required improvements are not completed within the period established or extended by the Town, the Letter of Credit may be declared in default and the Town may collect the amount payable thereunder. Upon receipt of such amount, the Town shall complete such improvements as were covered by the Letter of Credit and are commensurate with the extent of building development which has taken place in the subdivision or development, not exceeding in cost, however, the amount collected upon the Letter of Credit.

1.7.10. CHECKLIST FOR DEDICATION OF LAND DEVELOPMENT PROJECTS.

	<u>DATE</u>
1. Construction of All Dedicated Utilities Completed	_____
2. Testing of All Dedicated Utilities Completed	_____
3. Water Sample Analysis Received	_____
4. NYS Department of Health Completed Works Certificate	_____
5. Sanitary Sewer System Approved by NYSDEC	_____
6. Construction of Dedicated Roads Completed	_____
7. Grading & Seeding of R-O-W Completed	_____
8. Construction of All Drainage Facilities Completed	_____
9. Street, Parking Lot and Area Lighting Systems Completed	_____
10. Utility Easements Received from Developer	_____
11. Monuments & Property Corner Markers Set	_____
12. Special use districts (water, sewer, drainage, sidewalk, lighting) are formed	_____
13. Street & Traffic Signs in place	_____
14. Street & Traffic Signs Placed	_____
15. Record Drawings Completed by Developer	_____
16. Maintenance Bond Posted by Developer	_____

17. Final Release from LOC Approved by Town Board _____

18. Town Board Resolution Accepting Dedicated Facilities _____

1.8. SUBMISSION REQUIREMENTS FOR REVIEW.

Chapter 130 Town of Parma Code specifies the application requirements for sketch (conceptual), preliminary and final plan approvals. In addition to those requirements, the following are required.

1.8.1. CONCEPT/SKETCH PLANS

The Concept or Sketch Plan is an informal schematic presentation of existing features and of proposed development, and shall provide the following information:

1. Plan size not more than 34" x 44".
2. Scale not less than 1" = 200'.
3. Name or title of proposed project.
4. Name and address of subdivider or developer.
5. Name, address, seal and signature of developer's Engineer or Surveyor.
6. Written, clear statement of developer's intent.
7. North arrow, graphic scale, date and general location map.
8. Names and Tax I.D. Numbers of site owner and adjacent lands.
9. Ground contours for the parcel and parcels adjacent to the tract to be subdivided or developed, at intervals of not more than ten (10) feet of elevation.
10. All pertinent topographic features within the site and the adjoining tract, including existing buildings, watercourses, water bodies, wetlands, floodplains and wooded areas. Features to be retained and to be removed shall be so indicated.
11. If the subdivider intends to develop the tract in stages, the entire tract shall be shown, with anticipated stages and time schedule indicated. All other lands contiguous to the proposal owned by the subdivider shall be shown on the map with approximate area.
12. Major subdivisions and developments shall include an Engineer's preliminary report on soil and groundwater conditions based on at least one (1) test pit [eight (8) feet minimum depth for each ten (10) acres of development.
13. Proposed street lines, lot lines, easements, and areas to be dedicated.

14. Zoning district within the tract and any other legal restrictions of use.
15. Schematic plan of water system and proposed source of water supply.
16. Schematic plan of sanitary sewer system.
17. Major subdivisions and developments shall include a drainage study map with schematic plan of proposed system for stormwater drainage and erosion control.
18. Schematic plan of electric distribution system, gas mains, and telephone and T.V. cables.
19. Location of proposed project in relation to identified wetlands and to 100-year flood plain.
20. Covenants, easements or deed restrictions affecting the proposed subdivision.

1.8.2. PRELIMINARY ENGINEERING REPORT.

A preliminary engineering report is required as part of the preliminary plan review for all major subdivisions and major developments and shall include as a minimum the following information:

1. Basic project information including total acreage, number of lots, minimum lot size, estimated population, phasing of project, and general description of proposed development.
2. Water system preliminary design including estimated consumption, source of supply, pressures, and computation of required and available fire flows.
3. Sanitary sewer system preliminary design including estimated flows and summary of design data.
4. Traffic Impact Analysis.

1.8.3. PRELIMINARY DRAINAGE REPORT.

A preliminary drainage report is required as part of the preliminary drainage plan for all major subdivisions and for other projects when necessary in the opinion of the Town Engineer or the Highway Superintendent, and shall include as a minimum the following information:

1. Run-off calculations from the undeveloped site and from the developed site. The United States Department of Agriculture's Technical Release 55 (TR-55) shall be utilized for all stormwater runoff and storage volume calculations.
2. Storm sewer, culvert and channel sizing, showing the basis of design.
3. Stormwater management facilities shall be designed in accordance with the Unified Stormwater Sizing Criteria as outlined in the NYS Stormwater Management Design Manual. Specifically, the drainage

report shall include calculations for: Water Quality Volume, Runoff Reduction Volume, Channel Protection Volume, Overbank Flood Control Criteria, and Extreme Flood Control Criteria.

4. Stormwater Pollution Prevention Plan and Erosion and Sediment Control Plan shall be in accordance with the NYS DEC Regulations and any local related codes.

1.8.4. PRELIMINARY PLANS AND PLATS

In addition to the requirements for the Concept Plan, the following information shall be provided:

1. If more than one sheet is required to show the entire project, an index map showing match lines shall be provided.
2. Scale not less than 1" = 50'.
3. Property boundaries including bearings and distances.
4. Existing culverts, watermains, storm sewers and sanitary sewers nearby and within the development, with their location, size, type and approximate elevation and gradients.
5. A tracing overlay showing soils and their classification and those areas, if any, with moderate to high susceptibility to erosion. For areas with potential erosion problems, the developer shall also include a description and outline of existing vegetation.
6. Existing streets immediately adjoining and within the development and the distance to the nearest major street intersection.
7. The approximate lines and grades of proposed streets and sidewalks, and the names of the proposed streets.
8. A preliminary grading plan of the site, showing locations and approximate size of cuts and fills and cross sections for any final grading steeper than three (3) horizontal to one (1) vertical.
9. The approximate lines of proposed lots, the acreage contained in each lot and lot numbering.
10. The approximate lines and purposes of proposed easements.
11. The approximate location and dimensions of areas proposed for parks, playgrounds or other permanent open space.
12. The location of any municipal boundary, existing special district lines and existing zoning and zoning district lines within the tract.
13. Indications of any potentially nonconforming lots, showing required and actual area, yards and setbacks.
14. Preliminary plan of water system including water main sizes and hydrant locations.

15. Preliminary plans and profiles of sanitary sewers showing manhole stationing, size of sewers, surface and invert elevations at manholes, grade of sewers between adjacent manholes, and details of all standard and special appurtenances.
16. Preliminary drainage plan and erosion control plan including details of standard and special structures and appurtenances. The drainage plan should include grades at least 50-feet beyond the limits of the site and where applicable to the receiving stream
17. Preliminary plan of street lighting, electric distribution system, gas distribution system, and telephone and T.V. cables.

1.8.5. FINAL ENGINEERING REPORT

The final engineering report for major subdivisions and major developments shall expand on the information included in the preliminary engineering report, and shall include final design computations. Any significant changes from the preliminary report shall be explained in detail.

1.8.6. FINAL DRAINAGE REPORT

The final drainage report for major subdivisions and major developments shall expand on the information included in the preliminary drainage report, and shall provide the following additional information:

1. Final design data and computations of storm drainage and detention facilities.
2. Specific erosion and sedimentation control measures during construction.

1.8.7. FINAL PLANS AND PLATS

Final subdivision plans for major subdivisions and major developments shall include the following separate sheets:

1. Subdivision Plat Record Plan.
2. Grading and Drainage Plan.
3. Utility Plan.
4. Landscaping Plan.

In addition to the requirements for the Concept Plan and the Preliminary Plans, the following information shall be provided on the final plans:

1. Name, address and signature of owner of record.
2. The layout of proposed lots, including lot numbers and acreage of each lot.
3. Lines and grades of proposed streets.
4. Typical cross-sections of proposed streets.

5. Profiles of proposed streets.
6. Grading plan showing existing and proposed contours at intervals of not more than two (2) feet. Where drainage and grading concerns are critical in the opinion of the Town Engineer, the grading plan shall include contours at 1-foot intervals and spot elevations.
7. Location of all proposed buildings.
8. Final plans, profiles and details of sanitary sewer system.
9. Final plans, profiles and details of storm drainage system including detention facilities and erosion control.
10. Final plans and details of water distribution system.
11. Proposed location of monuments.
12. Landscaping plan for street trees, including varieties and minimum size, and existing trees to be preserved.
13. Final plan of street lighting and on site lighting.
14. Layout of parking lots including: handicap parking spaces, vehicular traffic areas, pedestrian traffic patterns, curbs, bollards, parking bumpers and sidewalks.
15. Location of storage areas for refuse, snow, maintenance equipment, recyclables and miscellaneous outdoor storage.
16. Approval Block for signatures by the Town Engineer, Highway Superintendent, Building Inspector and Planning Board Chairperson.
17. Standard Plan Notes.

1.8.8. STANDARD PLAN NOTES.

All site plans shall include the Standard Plan Notes included in the Standard Details.

SECTION 2. DESIGN STANDARDS

2.1. GENERAL

The development of land shall conform with zoning regulations established by the Town. It shall also conform with all appropriate laws, rules, and regulations established by all governing bodies having or claiming jurisdiction over various phases of the development

Where these Standards impose greater restrictions than are imposed by the provision of any law, ordinance, regulation or private agreement, these Standards shall control. Where greater restrictions are imposed by any law, ordinance, regulation, or private agreement than are imposed by these Standards, such greater restrictions shall apply.

2.2. REFERENCES TO OTHER SPECIFICATIONS

References to other standards and specifications shall mean that the applicable portions thereof shall be followed as if the specifications were actually incorporated in these Standards. It shall be understood that such references shall be to the latest edition or revision thereof, including all addenda.

2.3. RESPONSIBILITY FOR DESIGN

Developers are responsible for providing sound engineering design of all facilities, subject to review by the Town. The design shall be prepared by a New York State licensed professional engineer experienced in the design of such facilities. Design information, engineering reports, plans and specifications shall provide the information required by these Standards and additional information that may be required by the Planning Board.

Boundary surveys shall be performed and certified by a licensed land surveyor.

Approval of plans, reports and related documents and/or acceptance of any dedicated facilities by the Town does not indemnify the Developer, his engineer or other representatives of developer of the ultimate responsibility for the proper design and function of the proposed facilities.

2.4. WATER DISTRIBUTION SYSTEM

2.4.1. GENERAL.

Public water supply shall be provided, wherever practical.

2.4.2. PUBLIC WATER SYSTEMS.

Design shall conform to the following standards supplemented and superseded by additional requirements as listed.

1. Recommended Standards for Water Works, by Great Lakes – Upper Mississippi River Board of State and Provincial Public Health and Environmental Managers, latest edition.

2. Fire Suppression Rating Schedule, by Insurance Services Office of New York.
3. Design and materials shall be in accordance with the Monroe County Water Authority.

2.5. SANITARY SEWER SYSTEMS

2.5.1. GENERAL.

Public sanitary sewers shall be provided, wherever practical.

2.5.2. PUBLIC SANITARY SEWER SYSTEMS.

Design shall conform to the following standards supplemented and superseded by additional requirements as listed:

1. Recommended Standards for Wastewater Facilities, by Great Lakes – Upper Mississippi River Board of State and Provincial Public Health and Environmental Managers, latest edition.
2. Materials shall be in accordance with Section 3. Construction Standards and construction shall conform to Section 4. Standard Details.
3. Manholes shall be spaced at intervals not greater than 300 feet. Where practical, manholes should be placed near property lines. Manholes located in driveways and sidewalks should be avoided.
4. Depths of sewers shall be sufficient to serve basements of all houses in the development.
5. A drop of 0.3 feet shall be provided through each manhole for all changes in horizontal alignment.
6. Building sewers shall be 4-inch diameter minimum, at a minimum slope of ¼-inch per foot.
7. Cleanouts shall be provided for building sewers at all horizontal bends and at a maximum distance of 100 feet.
8. A vertical separation of two (2) feet shall be provided between parallel sanitary sewers and storm sewers to provide clearance for crossing of building sewers and drain.

2.5.3. PUMPING STATIONS AND FORCE MAINS.

Pumping station will be permitted only where gravity service is not practical. Design shall conform to the following standards supplemented and superseded by additional requirements as listed:

1. Recommended Standards for Wastewater Facilities, by Great Lakes – Upper Mississippi River Board of State and Provincial Public Health and Environmental Managers, latest edition.

2. Materials shall be in accordance with Section 3. Construction Standards and construction shall conform to Section 4. Standard Details.
3. Equipment shall be of similar type and manufacture as equipment in existing pumping stations, in the Town of Parma. In general, above ground, vacuum primed pump stations shall be provided.
4. All pump stations shall be equipped with standby electrical generators. Generators shall include: automatic transfer switches, telephone dialers, weatherproof housings and sound attenuating equipment. Where possible generators shall utilize natural gas fuel. Other fuels and use of portable generators will be subject to approval by the Town.

2.6. STORM DRAINAGE SYSTEMS

2.6.1. GENERAL.

Storm drainage systems shall be provided to convey stormwater runoff from within the development and from the upland watershed area along natural direction of drainage.

Drainage facilities shall include the street drainage system, a system of back-lot-line drainage swales, main drainage channels through the development, and stormwater management facilities.

Generally, preservation and improvement of natural streams, channels and swales within the development is preferable to the construction of new drainage channels, and whenever practicable, such watercourses shall be preserved.

The preservation and improvement of streams and channels downstream of the proposed development shall be required whenever such watercourses are subject to potential overflow, erosion or siltation as a result of runoff from the development.

2.6.2. DESIGN STANDARDS.

Design of drainage facilities shall conform to the following standards supplemented and superseded by additional requirements as listed:

1. ASCE Manual of Engineering Practice No. 37, Design and Construction of Sanitary and Storm Sewers by American Society of Civil Engineers.
2. Urban Hydrology for Small Watersheds, Technical Release No. 55 (TR-55) by Soil Conservation Service, U.S. Department of Agriculture.
3. New York State Stormwater Management Design Manual.
4. Materials shall be in accordance with Section 3. Construction Standards.

5. Manholes shall be spaced at intervals not greater than 300 feet. Where practical, manholes should be placed near property lines. Manholes located in driveways and sidewalks should be avoided.
6. Minimum size of storm sewers shall be 12-inch diameter pipe, except as otherwise permitted by these Standards.
7. Minimum velocity in storm sewers shall be 3 feet per second when flowing full.
8. Storm sewers shall be designed with uniform grade and straight alignment between manholes, outlets, and drop inlets.
9. Drop inlets shall be located at intervals not greater than 300 feet, at low points, and at street intersections. Drop inlets located at driveways and sidewalks should be avoided.
10. Swales and turf-lined channels shall be designed with slopes of not less than 1.0%.

2.6.3. HYDROLOGIC DESIGN.

Storm sewers and other drainage facilities for drainage areas up to 1,000 acres shall be based on a design flow with a minimum return interval of 10 years.

The design of drainage facilities for larger drainage areas and for natural watercourses channels shall be based on the drainage area according to the following:

<u>Drainage Area</u>	<u>Return Interval</u>
1000 acres to 4 sq. miles	25 years
4 sq. miles to 20 sq. miles	50 years
20 sq. miles and above	100 years

2.6.4. STORM SEWERS AND CHANNELS.

Storm sewers and channels shall be designed to convey the anticipated runoff from within the development as well as all future development from the upstream or upland watershed area.

The design shall be based on the Soil Conservation Service Technical Release 55 (TR-55) Method using the appropriate storm return interval.

2.6.5. OPEN CHANNELS.

Only natural drainage channels may be continued as open channels. Street drainage system for major subdivisions shall be designed with storm sewers.

2.6.6. DETAILS OF HYDRAULIC STRUCTURES.

Complete and sufficient details of hydraulic structures shall be submitted as part of the plans. This includes, but is not limited to, cross-sections of drainage channels, erosion control facilities, special manholes, and all such

other items as may be necessary to establish fully the methods and materials to be followed in construction.

2.6.7. SURCHARGING OF DRAINAGE FACILITIES.

Storm drainage systems shall be designed so that surcharging will not cause backup or flooding of basements. The effect of a 25-year storm shall be studied by calculating the high water elevation, and evaluating the operation of the storm drainage and detention facilities under such flows.

2.6.8. BUILDING AND LOT STORM DRAINAGE.

1. Finished Grade Adjacent to Buildings.

Finished grade adjacent to building walls shall be a minimum 1-foot higher than the edge of pavement for standard subdivision development. In minor developments where front setbacks exceed 150 feet and/or where natural drainage characteristics would be better utilized by draining away from the street, this requirement may be waived. In any case provisions shall be made for positive drainage of each lot by designing a minimum grade of 2.0% away from the building to side-lot and back-lot swales, natural drainage channels, or drains.

2. Roof and Basement Drainage.

All roof drainage shall be directed to surface drainage swales. Roof drains must be directed away from building structures or other areas that may cause nuisance or property damage. If the Developer chooses to direct roof drainage to a stormwater lateral, the Developer's Engineer shall size the lateral and stormwater management facility accordingly. Provisions shall be made for disposing of basement drainage into the street drainage system. Basement floors shall be at an elevation higher than the pavement to permit the street drainage system to be fully surcharged without causing backup or flooding of basements. In lieu of this, the developer may provide that basements shall be drained with sump pumps and appropriate check valves. Laterals serving basement drains shall be minimum 4-inch diameter pipe. The Developer's Engineer shall substantiate pipe sizes.

In special conditions, where topography permits, basement drainage may be conveyed to drainage swales if abutting or downstream properties will not be adversely affected. In such instances the basement floor shall be designed above the project design flood elevation to prevent backup or flooding of the basement.

3. Dry Wells.

Dry wells shall be used for disposing roof drainage where storm sewers are not available and soil conditions are suitable. Dry wells shall be sized using minimum 10-year storm. Dry wells shall be designed in accordance with the NYS Stormwater Design Manual.

4. Restriction.

Laundry, sanitary, floor drains or kitchen wastes shall not be discharged to storm drainage systems. Drain connections shall be in accordance with the appropriate building and plumbing codes.

5. Grading.

Lots shall be graded to provide positive drainage. Runoff from uphill lots shall be conducted around and across downhill lots along side-lot and back-lot swales.

Grading shall be designed to prevent runoff from adjacent lots draining against buildings.

2.6.9. STORM WATER MANAGEMENT FACILITIES.

Detention or retention ponds, sedimentation basins and related control measures shall be provided where in the judgment of the Town such facilities may be required for proper drainage control.

The United States Department of Agriculture's Technical Release 55 (TR-55) shall be utilized for all stormwater runoff and storage volume calculations.

Stormwater management facilities shall be designed in accordance with the Unified Stormwater Sizing Criteria as outlined in the NYS Stormwater Management Design Manual. Specifically, the facilities shall meet the requirements for: Water Quality Volume, Channel Protection Volume, Overbank Flood Control Criteria, Runoff Reduction and Extreme Flood Control Criteria.

Stormwater Pollution Prevention Plan and Erosion and Sediment Control Plan shall be in accordance with the NYS DEC Regulations.

If the Stormwater Management Facility is to be dedicated to the Town, the selection of the specific design shall be at the discretion of the Town. Considerations as to long-term reliability ease of maintenance, and cost of operations will be evaluated in the selection.

The Town reserves the right to establish more restrictive requirements if the proposed development site caused downstream flooding even in its natural, undeveloped condition. The Town may require an impoundment area, and storm sewers and culverts of sufficient size and type to correct the existing downstream flooding conditions.

2.7. EROSION AND SEDIMENT CONTROL

2.7.1. GENERAL.

To control siltation and erosion resulting from land development, the developer shall implement an erosion and sediment control plan. The erosion and sediment control plan shall be in accordance with the requirements of the NYSDEC State Pollution Discharge Elimination System (SPDES) General Permit for stormwater discharge.

It is the developer's responsibility to certify that the design and construction specifications for the erosion control measures are adequate and meet all requirements.

2.7.2. STEEP SLOPES.

Development in steep slope areas is subject to the guidelines as follows.

1. Required Information.

Development proposals shall be of sufficient detail to show site grading, building site locations, drainage facilities, erosion and sedimentation control measures, stream channel improvements and location of roads.

2. Grading of Building Sites.

3. Padding to provide level building sites may be designed only when sufficient information is developed to clearly demonstrate that the overall design of the site will not have an adverse environmental effect or negative appearance.

4. Design Principles.

- a. Design in steep slope areas shall include, but not be limited to, the following principles:
- b. Landscaping of areas around structures to make them compatible with the natural terrain.
- c. Shaping, grouping and placement of structures to complement the natural landscape.
- d. Shaping of essential grading to complement existing land forms.
- e. Retaining outstanding natural features such as the highest crest of the hill, natural rock outcroppings, particularly desirable trees and vegetation, and other unique features.
- f. Land within the hill area in excess of 30% slope should not be developed as individual residential lots.

2.7.3. FLOOD HAZARD CONTROL.

Inundation and excessive groundwater seepage shall be controlled by site grading and by the establishment of adequate elevations of buildings, building openings and roadways above the project design high water levels.

Particular care shall be used in the design of developments in the vicinity of designated flood plain areas as defined by the National Flood Insurance Program or known high groundwater problem areas. The effect of such development on upstream and downstream areas and adjacent properties shall be considered, and adequate protective measures shall be included in the design.

Proposed developments within the special Flood Hazard Area as defined by the National Flood Insurance Program shall comply with the regulations required by the Flood Insurance Program and the Town of Parma's Flood Prevention Code. The Developer's Engineer shall establish the Base Flood Elevation for each impacted property.

Development within or adjacent to flood plains shall also comply with current Town requirements, the Building Codes of New York State and NYS Department of Environmental Conservation regulations.

2.8. ROADS AND STREETS

2.8.1. GENERAL.

Roads and streets shall be provided for convenient traffic flow and circulation, and for fire safety, emergency and maintenance access. Roads, streets and drives shall comply with the following designations:

1. Collector Road.

Dedicated main road or street used to carry traffic from local streets to primary or major thoroughfares, including the principal entrance streets of a development.

2. Town Road.

Local street which connects to a Primary Road, or Collector Road and which provides access to abutting properties and protection from through traffic.

3. Cul-de-Sac.

Dedicated or private Access Road open only at one end for access with a turnaround at the other end; limited to serving 20 housing units

4. Private Road.

Undedicated road on private right-of-way used as ingress and egress for up to three properties not fronting on a dedicated road or street. To assure the safety and welfare of the public private roads shall be built to the standards included in these regulations and will be subject to inspections to verify proper construction. The planning board may require a letter of credit to insure the proper construction and to cover inspection fees.

5. Driveway.

Undedicated access used for ingress and egress to one property.

2.8.2. DESIGN STANDARDS.

Design of roads, streets and drives shall conform to the following standards supplemented and superseded by additional requirements listed in these Town Standards.

1. A Policy of Geometric Design of highways and Street, by American Association of State Highway and Transportation Officials (AASHTO).
2. Geometric Design Guide for Local Roads and Streets, by American Association of State Highway Officials (AASHTO).
3. Residential Streets, Objectives, Principles and Design Considerations, published jointly by the Urban Land Institute, the American Society of Civil Engineers, and the National Association of Home Builders.
4. Materials shall be in accordance with Section 3. Construction Standards.
5. Minimum right-of-way widths, pavement widths, road sections, and other details shall conform to Typical Right-of-Way Sections and Private Road Details in Section 4. Standard Details.

2.8.3. HORIZONTAL DESIGN REQUIREMENTS.

Roads and streets shall be designed to conform to the following horizontal alignment requirements:

1. Minimum radius along the centerline of horizontal curves:

Primary or Major Thoroughfares	500 feet
Collector Roads or Streets	300 feet
Local Streets	150 feet
2. Minimum tangent along the centerline of road between horizontal curves shall be not less than 100 feet.
3. Stopping sight distance for each type of road shall be not less than:

Primary or Major Thoroughfares	450 feet
Collector Roads or Streets	225 feet
Local Streets	150 feet
4. Cul-de-Sacs shall not exceed 800 feet in length and shall have a turnaround with right-of-way radius of at least 60 feet, and pavement radius of at least 50 feet.
5. Layout of street systems in the development shall provide for access of adjacent future developments.
6. Temporary dead-end streets shall be provided with temporary turnarounds of the same dimensions as specified for permanent turnarounds.
7. Permanent Turnarounds may be allowed only under special circumstances. Permanent dead-end roads shall be avoided wherever possible. Where approved shall not exceed 800-feet from the nearest road with multiple means of ingress/egress, as measured from the centerlines. Dead-ends shall include provisions to terminate in a cul-de-sac. Where properties do not accommodate a cul-de-sac, a turnaround may be considered. Inc such cases, easements to accommodate future extension and connection to another public road

shall be provided.

8. Private roads and driveways shall meet the requirement of the Fire Marshal.

2.8.4. VERTICAL DESIGN REQUIREMENTS.

Roads and streets shall be designed to conform to the following vertical alignment requirements:

1. Minimum grade 0.50%.
2. Maximum grade for:

Primary or Major Thoroughfare	6.0%
Collector Road or Street	6.0%
Town Road	8.0%
Private Road, Private Drive & Driveway	10.0%
3. Vertical curves shall be provided for all changes in grade exceeding 1.0%.
4. Minimum length of vertical curves shall be as follows, unless site distance dictates a specific length. Minimum length 100' and 20 feet per 1% difference in grade for changes greater than 5%.

2.8.5. INTERSECTION DESIGN REQUIREMENTS.

Intersections shall be designed to conform to the following requirements:

1. Within 50 feet of intersections, streets shall be approximately at right angles and in no case shall the intersecting centerlines have an angle less than 75°.
2. Minimum pavement radius at intersections shall be not less than 35 feet.
3. Intersections of Primary or Major Thoroughfares shall be spaced not less than 1,000 feet between centerlines.
4. Intersections of Collector Streets by other streets shall be spaced not less than 800 feet between centerlines.
5. Minimum distances between centerlines of offset streets shall be not less than 400 feet.
6. Acceleration and deceleration lanes may be required by the Town along primary or major thoroughfares at principal entrance streets of developments.
7. Leveling areas shall be provided on all sides of intersections. Grades within the intersection should not exceed 1%. Grade should not exceed 1.5% for a distance of 50 feet from the intersections. From 50 feet to 100 feet, the grades should not exceed 3%.

8. Maximum pavement grade within intersections shall not exceed 1.0% in any direction.
9. Visibility for traffic safety shall be provided within triangular areas formed by the intersecting right-of-way lines and a sight line between points 50 feet from their intersection. There shall be no plantings or structures (other than a single post) in these triangular areas.

2.8.6. GRADING AND ROADSIDE SWALES.

Areas within street rights-of-way shall be graded to eliminate slopes steeper than one vertical in three horizontal. Roadside swales steeper than 6.0%, or where soil conditions require, shall incorporate special design to control erosion.

2.8.7. SIDEWALKS.

Sidewalks shall be provided for all new developments and where required by the Town for safety or convenience. Sidewalks will be required on one side of the road for new subdivisions. At the discretion of the Planning Board sidewalks may be required on both sides of the road, for high-density developments or where the proposed use will need to accommodate high volumes of pedestrian traffic. The minimum width of sidewalks shall be five (5) feet.

2.8.8. STREET TREES

The contractor shall place trees at the locations shown on the plans and as directed by the Planning Board. Trees shall be a min. of 1-1/2" diameter and placed nine feet inside the R.O.W. line or as otherwise directed by the Highway Supt. Spacing shall be at 100' intervals on both sides of the R.O.W. Shade trees shall be Emerald Queen Maple, Crimson King Maple, Shademaster Locust, Greenspire Linden, Marshall's Seedless Ash, Autumn Purple Ash; other varieties shall be Bradford Pear (maturity 30') and Campstre Maple (maturity 25') as required by the Planning Board or approved equal. Trees shall not be planted next to fire hydrants, house laterals and services. Trees will be required as requested by the Planning Board.

The Contractor shall replace, without cost to the Town, and as soon as weather conditions permit and within a specified planting period, all dead plants and all plants not in vigorous, thriving condition. The plants shall be free of dead or dying branches and branch tips, and shall bear foliage of a normal density, size and color. Replacements shall closely match adjacent specimens of the same species. Replacements shall be subject to all requirements stated in this Specification.

The contractor shall make all necessary repairs due to plant replacements. Such repairs shall be done at no extra cost to the Town.

The Guarantee of all replacement plants shall extend for an additional period of one year from the date of their acceptance after replacement. If replacement plant material is not acceptable during or at the end of the said extended guarantee period, the Town may elect subsequent replacement or credit for each item.

2.8.9. STREET NAMES.

All streets shall be named in accordance with Parma Town Code, Section 130-15 A (10). Names shall be sufficiently different in sound and spelling from other street names in the Town and municipalities contiguous to the Town so as not to cause confusion. The developers shall contact Monroe County Emergency services to verify that the proposed street name is acceptable.

A street which is a continuation of an existing street shall be the same name. Relating street names to features of local historical, topographical, or other natural interest is encouraged.

2.8.10. MONUMENTS.

Permanent monuments shall be provided at the following locations and shall be shown on the final subdivision plat:

1. All boundary corners and angle points of the parcel being subdivided.
2. In street right-of-way boundaries at all street intersections.
3. In street right-of-way boundaries at PC and PT of horizontal curves.

Monuments are required on one side of the street only, and at only one corner of intersecting streets. Adjacent monuments shall be intervisible.

Monuments shall be tied into the NYS Coordinate System where practical in the opinion of the Town Highway Superintendent or Town Engineer.

2.8.11. PROPERTY CORNER MARKERS.

Permanent markers shall be provided and installed by a NYS Licensed Surveyor for all property corners of each lot, and shall be in place upon completion of final grading of the lot and issuance of the Certificate of Occupancy.

2.8.12. ROAD DEDICATION REQUIREMENTS.

1. Policy.

All primary roads and collector roads serving a development shall be built to the appropriate Town design standards and dedicated to the Town. Internal Access Roads may be privately owned and maintained. These roads must be built to the appropriate design standards of the Town.

2. Dedication Requirements.

All roads offered for dedication must set through one winter season and be monumented before dedication will be considered. Prior to any road being accepted for dedication, it must be completed in conformance with the approved plans to the satisfaction of the Town Engineer.

3. Privately Owned Access Ways.

This section pertains to any commonly owned means of access to property. All proposals for commonly owned private access ways must be approved by the Highway Superintendent and the Planning Board and be made part of the subdivision review record. Private ownership must be clearly identified on the final subdivision map.

Prior to final approval of subdivision plans, an application for a homeowners association and a draft offering plan for the New York State Attorney General's Office must be filed with the Planning Board. An "exempt status" letter from the NYS Attorney General's Office may be filed in lieu of the application and offering plan. Should the commonly owned access not require a homeowners association, then reciprocal easement and a maintenance agreement must be approved by the Attorney for the Town and be placed in the deeds of the affected lots. A copy of the filed deed must be presented to the building department prior to a building permit being issued for an affected lot.

4. Surety.

Appropriate surety shall be required for all dedicated roads and commonly owned private access ways.

2.8.13. DRIVEWAY DESIGN REQUIREMENTS.

Design and location of driveways shall be in accordance with applicable requirements of NYSDOT Policy and Standards for Entrances to State Highways. These standards shall apply also to driveways entering on County and Town streets.

1. Vertical Alignment.

Driveways connected to roads with no curb or gutter shall slope away from the edge of road pavement at the same slope as the road shoulder, and the slope shall extend at least the full width of the shoulder so as not to create a bump or depression in the shoulder area.

Driveways connected to roads with curb or gutter shall slope towards the edge of road pavement at a minimum of 2% slope.

2. Horizontal Alignment.

Driveways shall conform to the horizontal alignment requirements of Driveway Details in Section 4. Standard Details.

3. General Requirements

Driveways shall be paved within the right-of-way. Residential driveways shall be minimum of 10-feet wide. Driveways longer than 100-feet shall include stationing to verify proper layout. Driveways longer than 400-feet shall be of a width and include bump-outs (passing areas) as recommended by the Town Highway Superintendent and Fire Marshal.

4. Application Requirements.

Written application including a plan and a profile of the driveway shall be submitted to the Highway Superintendent for approval.

2.9. STREET LIGHTING

2.9.1. GENERAL.

Lighting systems shall be provided for streets, parking lots and activity areas.

2.9.2. DESIGN STANDARDS.

Design shall conform to the following standards supplemented and superseded by additional requirements as listed:

1. National Electrical Code.
2. Requirements of Electric Utility.
3. Average illumination for each area and activity shall conform to recommendations of Illuminating Engineering Society.
4. The layout of street lighting shall provide the recommended light level based on the average illumination on the roadway surface when the illuminating source is at its lowest output, and when the luminaire is in its dirtiest condition.
5. Minimum Recommended Average Illumination levels shall be as follows:

Commercial Roadways – 0.8 footcandles
Mixed Roadways – 0.7 foot-candles
Residential Roadways – 0.4 foot-candles

Maximum Uniformity Ratio (average/minimum) shall be no more than 6:1.
6. Lights shall be provided at a minimum at intersections and curves.

2.10. OFF STREET PARKING

2.10.1 GENERAL.

Parking areas for commercial, industrial, business, multifamily and places of public assembly shall conform to the following standards:

1. Minimum turning radii for design vehicles and aisle widths shall be in accordance with AASHTO Standards.
2. Parking shall be in accordance with the NYS Uniform Fire Prevention and Building Code.

3. Minimum parking space dimensions shall be 9-feet wide and 18-feet long.
4. Parking areas shall be paved with at least 4-inches of asphalt or cement concrete pavement.
5. The perimeter of parking areas shall include curbs. Curbs shall be provided, where parking areas are adjacent to sidewalks, road rights-of-way or buildings. Curbs shall be minimum of 6-inch in height.

2.11. LIGHTING FOR PARKING LOTS AND PEDESTRIAN WALKWAYS

2.11.1 GENERAL.

1. These recommended levels are for typical conditions. During periods of non-use, the illuminance of certain parking facilities may be turned off or reduced to conserve energy.
2. All lighting shall be designed in accordance with the recommendations of the Illuminating Engineering Society of North America (IESNA) and International Dark-Sky Association.

Level	Horizontal Illuminance (min)	Vertical Illuminance (min)	Uniformity Ratio (ave/min)
<u>Parking Lots</u>			
Basic Maintained Illuminance	0.2	0.1	6:1
Enhanced Security Illuminance	0.5	0.25	6:1
<u>Sidewalks and Bikeways</u>			
Commerical Areas	1	2.2	3:1
Intermediate Areas	0.6	1.1	4:1
Residential Areas	0.2	0.5	6:1

2.12. LANDSCAPING AND BUFFERING

2.12.1 GENERAL.

All landscaping and buffering required by the Planning Board shall be designed by a New York State Licensed Landscape Architect or NYS Certified Nursery & Landscape Professional and included on the site plans for approval. Landscaping and buffers shall be maintained by the property owner. No modifications to the required landscaping and buffers, other than routine maintenance and replacement of oversized, dead or dying plantings, may be completed with site plan approval.

SECTION 3. CONSTRUCTION STANDARDS

3.1. GENERAL

3.1.1. PRELIMINARY MATTERS.

Site preparation, grading and construction of facilities shall not be started until the Final Site Plan or Final Plat has been approved by the Planning Board and all necessary signatures have been affixed on the drawings, and until the Letter-of-Credit has been received by the Town.

3.1.2. PRE-CONSTRUCTION MEETING.

A pre-construction meeting shall be held prior to the start of construction to review Town requirements and to establish the project schedule. The Developer, his Engineer, involved utilities, involved agencies and Contractor shall attend this meeting to discuss the project with Town representatives. It shall be the responsibility of the Developer's Engineer to coordinate the scheduling of this meeting.

3.1.3. INSPECTION.

All construction shall be subject to inspection by representatives of the Town. The Developer and his Contractor shall provide adequate access for such inspection at all stages of the work.

The inspector may stop the work when the Developer or Developer's contractor has no competent supervision in charge of his work, or when the work or materials do not meet these specifications, or when circumstances are such that continuance of the work will result in sub-standard work.

All costs related to engineering and inspection by representatives of the Town shall be paid by the Developer. An amount approved by the Town for engineering and inspection shall be included in the Letter-of-Credit.

3.1.4. RESPONSIBILITY FOR CONSTRUCTION.

The Developer is solely responsible for construction of all dedicated facilities in accordance with the approved plans, and all applicable regulations and Town standards.

Inspection during construction shall not imply acceptance of the work by the Town. If subsequent inspections, operation or occurrences reveal defects in the work, such defects shall be corrected by the developer to the satisfaction of the Town.

The development shall not be accepted for dedication until all construction of dedicated facilities is fully completed by the Developer and found to be satisfactory by the Town.

3.1.5. PROTECTION OF EXISTING UTILITIES AND STRUCTURES.

It is the Developer's and his Contractor's responsibility to locate and protect all existing utilities and structures before, during, and after excavation, in accordance with NYS Code Rule 753. Protect all utilities, services, and

systems, including public and private poles, conduits, water piping, storm drainage piping and culverts, and farm tiles, including related structures, in a manner acceptable to the representative of the Town and the owner of each utility, service, or system. Any damage done to any utility, service, or system shall be repaired at the Contractor's expense in a manner acceptable to the representative of the Town and the owner of the system. Where construction is near or underneath any pole, conduit, pipe, or similar structure, provide any necessary support.

Notify all utilities and the Dig Safely New York, Inc. (Telephone 1-800-962-7962) 2 to 10 days prior to any excavation.

Where excavations are within existing pavement and sidewalk areas, pavements and sidewalks shall be sawed or cut uniformly along the limits of excavation. All disturbed pavements, sidewalks, curbs and gutters shall be replaced by the Contractor to match the existing or remaining surfaces.

3.1.6. PERMITS AND TRAFFIC CONTROL.

The Developer and his Contractor shall obtain and comply with all necessary permits from the authority having jurisdiction for construction within and adjacent to public roads or as needed to complete the work.

Provide flagmen, signs, barricades, lights, and flashing signals for traffic control, safety and protection of the public as required by the authority having jurisdiction.

3.1.7. SHOP DRAWINGS AND MANUFACTURER'S INFORMATION.

The Contractor shall submit shop drawings for all materials to be incorporated in the dedicated facilities to the Developer's Engineer for review. Upon confirming that the shop drawings conform to the approved plans, specifications, and Town standards, the Developer's Engineer shall forward signed copies of such shop drawings to the Contractor and to the Town Engineer.

3.1.8. NOISE CONTROL.

All work shall be done in conformance with the Town of Parma Code Section 89 – Noise. Construction equipment and vehicles shall be maintained by the Contractor in good working condition to control leaks, noise and exhaust emissions.

Construction activity shall be restricted to the hours of 7:00 a.m. to 9:00 p.m. Special permission shall be obtained from the Town for activities that require continuous operation beyond the restricted hours. This restriction applies also to starting up and moving of construction equipment.

3.1.9. WEATHER CONDITIONS.

Work shall be suspended during unsuitable weather conditions. The Contractor shall take necessary precautions to protect all work, materials and equipment from damage or deterioration due to floods, rain, wind and snow storms. The mixing and placing of concrete, construction of pavements, gutters and sidewalks, laying of masonry, and installation of sewers and water mains shall be stopped during rain storms or other

unsuitable weather. Newly placed concrete and masonry shall be protected by suitable covering.

3.1.10. CONNECTION TO AND OPERATION OF EXISTING FACILITIES.

Connection to and operation of existing Town facilities is not permitted for any purpose, unless specifically authorized by a designated representative of the Town. It is strictly prohibited to operate existing hydrants, valves or other controls. Discharging sewage, groundwater or surface drainage to existing sanitary or storm sewer systems is also prohibited. Any person violating this restriction will be prosecuted to the full extent of the law.

Generally, connection to existing systems will not be permitted until all work on the new facility to be dedicated is completed, tested and found to be acceptable by the Town.

3.1.11. RECORD DRAWINGS.

Record drawings shall be prepared by the Developer's Engineer for all dedicated facilities, four (4) prints, one reproducible mylar film and computer drawing file shall be submitted to the Town prior to the request for dedication. Record drawings shall include the elevation, station and offset for all components of the dedicated facilities including: storm and sanitary laterals, wyes, cleanouts, catch basins, manholes, monuments, rims and inverts. Record drawings of grading plans shall be provided where critical grades, drainage facilities, swales, ponds and the like are included in the Work.

3.1.12. SITE SAFETY

The Developer is responsible for compliance with all safety associated with the completion of the Work, including compliance with the Occupational Safety and Health Act (OSHA).

3.1.13. CHECKLIST FOR NOTICE TO PROCEED FOR LAND DEVELOPMENT PROJECTS.

TOWN OF PARMA, NEW YORK

CHECKLIST FOR NOTICE TO PROCEED
FOR LAND DEVELOPMENT PROJECTS

1. Planning Board Approval of Final Plans or Plats.
2. Monroe County Department of Health Water System Plan Approval.
3. Monroe County Department of Health Realty Subdivision Approval.
4. Monroe County Department of Health.
5. Sanitary Sewer Plan Approval.
6. All permits and notices have been issued.
7. Utility Easements are filed.
8. Letter of Credit Posted with Town.
9. Pre-Construction Meeting Held.
10. All Legal and Engineering Review Fees Paid.

3.2. SITE PREPARATION

3.2.1 GENERAL.

No site work shall commence prior to final approval and items listed in 3.1.13 are completed. Site preparation consists of clearing and grubbing, topsoil removal and stockpiling, protection of existing facilities, providing temporary access, erosion and siltation control, and related work.

3.2.2 CLEARING AND GRUBBING

Clear and grub all areas of excavation, trenches, embankments, and areas to be graded by removing all trees, stumps, roots, brush and debris within the limits indicated on the drawings. All trees, shrubs and vegetation that are not to be removed shall be protected and preserved.

Arrange for disposal of clearing and grubbing materials satisfactory to the New York State Department of Environmental Conservation and the Town. Burning of debris in the work areas is not permitted.

All work shall be in accordance with applicable requirements of NYSDOT 201 – Clearing and Grubbing.

3.2.3. LAYOUT OF WORK.

The Developer is responsible for layout of all work on the project. All work shall be staked-out by experienced licensed surveying personnel in accordance with the approved plans. Stake-out shall be in sufficient detail

to provide correct horizontal locations and elevations of structures, pipes, roads and grading.

Stake-out shall be performed as the work progresses. Any stake-out that is disturbed shall be re-staked before continuing with the work.

3.2.4. TOPSOIL REMOVAL AND STOCKPILING.

Remove and stockpile topsoil from areas to be excavated and graded. Unless approved by the Town, topsoil shall not be removed from the project site and shall be retained until it is used in landscaping of project sites.

3.2.5 EROSION AND SEDIMENT CONTROL.

Erosion and sediment control shall be in accordance with the approved erosion and Sediment Control Plan and Stormwater Pollution Prevention Plan. Developer's Engineer shall be responsible for maintenance of records in accordance with the NYS DEC requirements.

3.2.6 TEMPORARY ACCESS.

Provide and maintain temporary parking areas and access roads to project sites for use by all Contractors on the project, and for delivery of materials.

Maintain the temporary roads and parking areas in serviceable condition until the permanent roads are completed.

3.2.7 PROTECTION OF WORK.

Where work is left uncompleted, because of weather or other reasons, it shall be protected. Road beds shall be left well drained. Sanitary sewers shall be so protected that surface water cannot enter. Sanitary sewers and storm drains shall be so protected that mud, silt and debris cannot enter.

3.3. GRADING, EXCAVATION AND RELATED WORK

3.3.1. GRADING.

Site grading shall be completed to within one (1) foot of finished grades and contours shown on the grading plan before starting any trench excavation, and shall include grading of lots, drainage channels, detention ponds, temporary siltation ponds, and roadways.

Graded areas shall be relatively smooth and free of ruts, depressions or mounds, and shall be graded for proper drainage.

3.3.2. TRENCH EXCAVATION.

Excavation shall include the removal of all materials encountered, including rock, necessary for the installation of piping, appurtenances and structures. Excavation shall also include separation and disposal of material that is not suitable for backfill and storing material that is suitable for backfill. All excavations shall be in accordance with OSHA requirements.

Trenches shall be excavated only so far in advance of pipe laying as necessary for installation of pipe and to comply with access requirements.

If encountered, rock may be loosened by blasting or other methods after review by the Engineer. The Contractor must take proper precautions to protect persons and property. Blasting operations shall be carried out only by experienced personnel. The Contractor shall obtain any permits and insurance necessary for blasting operations. Any damages resulting from rock excavation shall be the responsibility of the Contractor.

Rock, boulders and large stones shall be removed to provide a minimum clearance of 6 inches below and on each side of all pipes and a minimum clearance of 1½ feet around manhole risers.

3.3.3. SEPARATION OF BACKFILL MATERIAL.

Excavated material, which is suitable for backfill, shall be separated from earth excavation, which is unsuitable for backfill and rock, boulders, frozen earth, paving materials, concrete, and stones larger than 8 inches in their greatest dimension. These materials, which are not to be used for backfill, shall be hauled away and disposed of at a site to be arranged for by the Contractor and subject to the approval of the Department of Environmental Conservation.

3.3.4. DEWATERING.

Trenches shall be dewatered so that pipe is not installed in water. The Contractor shall provide pumping equipment and other methods for dewatering trenches. The discharge from dewatering equipment shall be conducted to sedimentation basins and silt traps before discharging to natural drainage channels, gutters, drains, or storm sewers. Surface water shall be diverted or otherwise prevented from entering excavations and to prevent damage to adjacent property.

Water shall not be allowed to soften the bottom of the trench. If the trench bottom becomes soft due to failure to keep the excavation dry, the softened material shall be removed and replaced with crushed stone.

3.3.5. MAINTENANCE OF BANKS.

Provide sheeting, bracing, and shoring of trenches in accordance with OSHA and as necessary to protect adjacent structures including poles, trees, pavements, pipelines, and to provide safe working conditions.

The methods to maintain the stability of banks must be in accordance with applicable laws, rules and regulations, and are the sole responsibility of the Contractor.

3.3.6. PIPE BEDDING.

Pipe bedding for water mains, water services and storm sewers shall be formed in solid, undisturbed earth except as otherwise specified. Water shall not be allowed to soften the bottom of the trench. The pipe bed shall be prepared accurately with hand tools so that the full length of the pipe is supported by the pipe bed. The bottom of the trench shall be checked before the pipe is lowered into the trench to make certain that the pipe to be laid will not exceed the allowable deflection. Recesses shall be excavated for pipe bells, so that the pipe does not rest on the bells. If the trench is

excavated below the required depth, the excess depth shall be filled with crushed stone cradle.

Trenches shall be excavated to a level 6 inches below the bottom of the pipe in rock areas or where the trench bottom contains stones. The foundation for the pipe in such areas shall be provided by the use of crushed stone cradle.

Trenches for sanitary and storm sewers and buildings sewers and laterals shall be excavated to a level 6 inches below the bottom of the pipe. The foundation for the pipe shall be provided by the use of crushed stone. The crushed stone shall be spread and shaped by hand to provide uniform support for the pipe for at least $\frac{3}{4}$ of the pipe diameter and shall extend for the full width of the trench.

Where the 6-inch depth of crushed stone is not adequate to provide a proper foundation for the pipe in the opinion of the Engineer, additional depth of crushed stone or cradle shall be used.

If any trench is excavated below the required depth as authorized by the Engineer, the excess depth shall be filled with crushed stone cradle.

Coupling or bell holes shall be prepared so that the pipe does not rest on the outer portion of the coupling or bell. Holes shall be of adequate size but must not be excessively large.

3.3.7. CRADLE MATERIALS.

Cradle materials for pipes, manholes, and building sewers shall be as follows:

1. Crushed Stone Cradle.

NYS DOT 703-02, Size No. 1 and 2 to provide a dense material that gives the maximum support to the pipe.

2. Concrete Cradle.

Where trench bottom is not suitable, as determined by the Town Engineer NYS DOT 501-2, Portland Cement Concrete, Class B with 1½-inch maximum slump shall be used. When approved by the Town Engineer, water may be omitted from the mix.

3.3.8 SPECIAL REQUIREMENTS AT STRUCTURES.

Excavation around manholes and other structures shall provide a clearance of 1½ feet. The excavation in the areas where pipes enter the structure shall be kept to a minimum.

Where any pipe passes through a structure excavation, concrete cradle shall be provided under the pipe for support. The concrete cradle with 2:1 side slopes shall extend from the pipe to the bottom of the excavation and shall support the pipe for a width equal to at least $\frac{3}{4}$ of the pipe diameter.

Provide uniform support with concrete cradle under manhole bases as detailed.

Special attention shall be given to keeping the excavation opened and dewatered so that work around the outside of structures can be completed properly.

3.3.9 SPECIAL REQUIREMENTS FOR BUILDING SEWERS.

Where building sewers pass through main sewer trench excavations, the foundation for the pipe and wye shall be provided by the use of concrete cradle. The concrete cradle shall extend the full width of the trench. The concrete cradle shall be shaped by hand to provide uniform support for the pipe and tee for a width equal to at least $\frac{3}{4}$ of the pipe diameter.

3.4. BACKFILL AND EMBANKMENTS

3.4.1. GENERAL.

Backfill and embankments consist of placing and compacting backfill material in trenches and around structures, and construction of embankments and fills, including maintenance of backfilled surfaces, disposal of excess excavated material, and related work, and shall generally conform to applicable requirements of NYSDOT 203.

Embankments and fills shall be completed before installation of piping and appurtenances are started.

3.4.2. MATERIALS.

In general, construct fills and backfill trenches with excavated material provided that the excavated material is suitable in the opinion of the Town Engineer. Where there is a deficiency of excavated material due to the rejection of a part thereof, use excess excavated material from other portions of the project.

Granular fill shall be used for backfill, where directed by the Town Engineer or where there is a deficiency of suitable or select excavated material on the project.

1. Suitable Excavated Material.

Dry excavated material from which all frozen material, pavement materials, cinders, ashes, refuse, sod, roots, organic material, rock or stones larger than 6 inches in the greatest dimension have been removed.

2. Select Excavated Material.

Select, dry excavated material from which all pavement materials, concrete, cinders, ashes, refuse, organic material, topsoil, sod, roots, frozen material, boulders, rock, or stones larger than 2 inches in the greatest dimension, or other material, which in the opinion of the Town Engineer is not suitable, have been removed.

3. Granular Fill.

NYS DOT 302-2.02C, Select Granular Fill with all particles passing a 4-inch square sieve.

3.4.3. EMBANKMENTS AND FILLS.

Construct fills and embankments using select excavated material within 2 feet of finished grade, and suitable excavated material below depths of 2 feet within finished grade. Place and compact fill material in layers not to exceed 12 inches and as specified under compaction requirements.

Rework embankment and fill that does not conform to these specifications to meet the requirements, or remove and replace the material with acceptable fill. Compact all fill material placed before the end of each workday. Grade the final layer placed each day for proper drainage to prevent ponding of surface run-off on the fill.

3.4.4. TRENCH BACKFILL.

1. General.

Trenches shall be backfilled immediately after installing the pipe and completion of work within the excavation. Backfill around each pipe shall be placed before installing the next length of pipe. Trenches shall be relatively dry during backfilling.

2. Pipe Sidefill and Safety Cover.

From the top of the pipe bed or cradle to a level one foot over the top of the pipe, backfill shall be select excavated material deposited by hand in 6-inch layers and compacted by tamping. Backfill shall be deposited in the trench for its full width on each side of the pipe simultaneously so as not to disturb the pipe.

3. Backfill Around Structures and Appurtenances.

Backfill around manholes, inlets, valve boxes and hydrants shall be select excavated material deposited in accordance with the requirements for backfill around pipe to a level one foot over the top of the entering pipes. Above this level, backfill shall be deposited uniformly around the structure or appurtenance in 12-inch layers and thoroughly compacted.

4. Backfill Above Safety Cover.

Above the levels specified for pipe sidefill and safety cover, the trench shall be backfilled and compacted by mechanical methods. For each section of trench, the Town Engineer shall review the method of backfill and compaction considering the type of backfill material and the finished ground surface above the pipe.

5. Backfill Under Pavement Areas.

Backfill under roadways and surfaces normally subject to vehicular traffic, including pavements and gutters, shall be select excavated

material or granular fill uniformly placed, leveled, and compacted in 12-inch layers using mechanical compactors.

3.4.5. COMPACTION.

Compaction methods employed shall produce the specified compaction, prevent subsequent settlement, and provide the required support for proposed construction on the compacted subgrade. Proposed compaction methods shall avoid damage to existing facilities and to completed construction.

Prior to starting placement and compaction of backfill and embankment, submit in writing to the Town Engineer a description of the methods and equipment proposed for compaction. The Engineer will review this information considering the type of backfill material and the finished ground surface. If the proposed method does not provide the compaction required, alternate methods shall be adopted until the required compaction is achieved.

Determine the moisture content of backfill or fill material, and adjust it to provide optimum moisture content for the required compaction

The minimum compaction requirements are expressed in percent of the maximum dry weight density of the material as determined by ASTM D698. Minimum compaction requirements for backfill and embankment shall generally conform to the following, unless otherwise specified:

	<u>Maximum Layer Before Compaction</u>	<u>Minimum Compaction</u>
1. Embankments.		
Under roadways, shoulders, gutters and sidewalks	12 inches	95%
All other areas	24 inches	85%
2. Trench Backfill.		
Under pipe and pipe cradle	6 inches	95%
Pipe sidefill and safety cover to 1 foot over tops of pipe	8 inches	93%
Under roadways, shoulders, sidewalks, parking areas, and gutters	12 inches	95%
All other areas	24 inches	85%
3. Structure Backfill.		
Around all structures and appurtenances including man-holes, inlets, hydrants, and valve boxes	12 inches	95%

3.4.6. DENSITY TESTS.

The Town may require density tests of compacted material to confirm the actual compaction. Such tests shall not exceed a test for every 200 C.Y. of embankment, and every 100 feet of trench backfill. The Developer or his Contractor shall arrange with a testing laboratory to perform density tests, if required by the Town, at the locations directed, and furnish a written report of each test to the Town. Density tests shall be made in accordance with AASHTO Standard T-238.

3.4.7. SITE MAINTENANCE AND CLEANUP.

The Developer shall maintain the site in a neat and safe condition. Surplus materials, debris, rock and unsuitable excavated material shall be removed and disposed of as the work progresses.

Dust shall be controlled so as not to affect adjacent developed areas, roads and streets.

Gravel run-off areas shall be provided for construction traffic leaving the site to control tracking and deposits of soil from the site on adjacent roads and streets. The Developer and his Contractor are responsible for removing tracked or dropped material as often as required to keep roads and paved areas clean.

3.5. WATER DISTRIBUTION SYSTEM

3.5.1. MATERIALS FOR WATER MAINS AND SERVICES

All materials shall meet the requirements of the Monroe County Water Authority.

3.5.2. INSTALLATION OF WATER MAINS AND APPURTENANCES.

All work shall meet the requirements of the Monroe County Water Authority.

3.5.3. INSTALLATION OF SERVICES

All work shall meet the requirements of the Monroe County Water Authority.

3.5.4. PREPARATION FOR USE.

Prior to use all water system components shall be pressure tested, disinfected and sampled in accordance with the Monroe County Water Authority and the Monroe County Department of Health.

3.6 SANITARY SEWER SYSTEM

3.6.1 MATERIALS.

1. Polyvinyl Chloride (PVC) Main Sewer.

ASTM D3034 SDR 35, PVC Plastic Gravity Sewer Pipe with elastomeric gasket joints. Provide 4-inch diameter branch fittings.

2. Ductile Iron Pipe (DIP) Main Sewer.

AWWA C151/ANSI A21.51, thickness Class 50 with ANSI A21.4 cement mortar lining and seal coating inside, bituminous coating outside, ANSI 21.11 push-on joints.
3. Polyvinyl Chloride (PVC) Building Sewer.

ASTM D3034-SDR 21, PVC Plastic Gravity Sewer Pipe and fittings with elastomeric gasket joints.
4. Polyvinyl Chloride (PVC) Force Main.

ASTM D2241 SDR 21, PVC Pressure Rated Pipe, 200 psi pressure rating, with elastomeric gasket bell ends, PVC fittings with elastomeric gasket bell ends, PVC fittings and adapters.
5. Stone Cradle Material.

NYSDOT 703-02, Size No. 1 and 2.
6. Concrete.

Concrete for backing, bracing, encasement and cradle shall be NYSDOT 501-2, Portland Cement Concrete, Class B, 2-inch maximum slump. Water may be omitted from the mix for cradle and encasement when approved by the Town Engineer.
7. Cleanouts.

Fabricated from ASTM D3034 SDR 21, PVC Plastic Gravity Sewer Pipe and fittings, and cast iron screw plugs as shown in the Standard Details. In paved areas cleanouts shall be installed with a cleanout cover, Model 4155-074C, as manufactured by Syracuse Castings or approved equal, with the words "Sanitary C.O." embossed on the lid.
8. Manholes.
 - a. Bases, Risers, and Cone Tops.

Precast reinforced concrete manhole units conforming to NYSDOT 706-04 requirements for circular manhole units and ASTM C-478. Refer to Standard Details for dimensions, minimum base slab reinforcing steel and other features.
 - b. Cover Slabs.

Precast reinforced concrete cover slabs. NYSDOT 555-2, Structural Concrete, and Class A conforming to NYSDOT 501-1, 501-2, and 501-3 and ASTM A-615, grade 60 deformed reinforcing steel, and other features.

- c. Base, Riser, and Cover Slab Joints.

Tongue and groove with continuous solid rubber ring gasketed joints conforming to ASTM C-443.
- d. Pipe Connections.

Pipe to manhole connections shall be synthetic rubber with stainless steel retaining rings and clamps meeting ASTM C 923 Standard Specification for Resilient Connectors between reinforced concrete Manhole Structures, Pipes, and Laterals or equal. All flexible manhole seals shall be sized for inlet and outlet pipes to provide a watertight seal sufficient for required vacuum and leak testing.
- e. Manhole Steps.

Manhole steps shall be ½" grade 60 steel with copolymer polypropylene plastic covering, model PS2-PF as manufactured by M.A. Industries.
- f. Manhole Frames and Covers.

Cast iron frames and covers, uniform quality, free from blowholes, porosity, hard spots, shrinkage defects, cracks, fins, burrs, sand and slag. Cleaned by sand blasting. Asphalt coated. Materials shall conform to ASTM A-48, Class 30. Bearing surfaces shall be ground or machined. Designed to carry a wheel load of 16,000 pounds plus impact. Total weight of frame and cover shall be not less than 370 pounds. Covers shall be cast with the words "SANITARY SEWER" as part of the design.

Standard frames and covers with indented top design as manufactured by Syracuse Castings Sales Corp., Catalog No. 1032; or equal.
- g. Concrete for Benches and Inverts.

NYSDOT 555-2, Structural Concrete, Class A conforming to NYSDOT 501-1 and 501-3.
- h. Dampproofing.

The entire exterior and interior above the crown of the highest pipe shall be coated with two 3.6 wet mil coats of tar base paint. Bitumastic Black Solution as manufactured by the Detroit Graphite Company, or equal.

The interior walls below the crown of the highest pipe and bench shall be coated with two coats of Sika-Guard Hi-Build 667 Duralkote. The second coat shall contain non-slipping agents on the bench.

- i. Non-Shrink Grout.

Fast setting, non-shrink, non-metallic, high strength, water resistant, pre-mixed grout. Octocrete as manufactured by Penncrete Products Company, or equal.
- j. Grade Rings.

ASTM C-478 precast reinforced concrete rings, 2 inches thick, 8 inches wide and 24 inches inside diameter.
- k. Brick.

ASTM C-32 sewer and manhole clay or shale brick.
- l. Mortar.

ASTM C-270, Type M. Mix design by volume shall be one part Portland Cement, one part masonry cement, and five parts mortar sand. Lime shall not be used.
- m. Concrete Curing Compound.

ASTM C-309 Liquid membrane-forming compound for curing concrete.
- n. Drop Pipe.

Ductile Iron Pipe, AWWA C151/ANSI A21.51, thickness Class 50, with ANSI A21.4 cement mortar lining. ANSI A21.11 push-on joints. Provide an adaptor for jointing the drop pipe to the main sewer tee.
- o. Drop Pipe Bend.

ANSI A21.10 cast iron bend with a plain end and a push-on joint bell end or mechanical joint end.
- p. Manhole Cover Inserts.

High-density polyethylene bowl, ASTM D1248, Class A, Category 5, minimum thickness 1/16 inch. Black, closed cell neoprene gasket, ASTM-D-1056-73T, cemented to the underside of the insert bowl rim by the manufacturer.

One gas pressure relief and one vacuum relief valve installed in the insert bowl. Valve bodies manufactured of high-density polyethylene with neoprene valve plugs confined with stainless steel springs. The pressure and vacuum relief valves shall release at a differential pressure of 1 psi.

Model NEC-4 as manufactured by Preco Industries, Ltd., or equal.

3.6.2 INSTALLATION OF MAIN SEWERS AND BUILDING SEWERS

1. Handling Materials.

The Contractor shall inspect pipe for damage before unloading. The pipe shall be unloaded in accordance with the manufacturer's instructions and with care to avoid damage. Pipe shall not be dropped or bumped against pipe already on the ground or any other object on the ground. Prevent damage to the pipe ends. Keep interior and ends of pipe free from dirt.

The pipe shall be lowered into the trench to prevent impact and damage. As the pipe is lowered, the ends and interior of the pipe shall be inspected for cleanliness and shall be cleaned, if necessary. Do not allow the pipe to be dragged along the ground or trench bottom.

2. Making Joints.

Joints shall be made in accordance with the manufacturer's instructions and direction of the Engineer. The interior of the pipe and coupling already in place shall be cleaned, the gasket inserted in the groove, lubricant applied, and the length of pipe to be installed pushed home. A gauge shall then be used to verify that the rubber gasket is located in the groove all the way around.

The pipe joint shall not be made under water.

3. Other Installation Requirements.

Pipe installation shall commence at the lowest elevation and shall terminate only at manhole. Pipe bells or couplings shall be laid on the upstream end.

Each section of pipe shall rest on the prepared pipe bed or cradle for the full length of the barrel. The pipe shall be laid true to established line and grade to within ¼ inch. Any pipe that is disturbed after installation shall be taken up and re-laid.

If a trench shield is used, the pipe joint shall not be covered until after the shield has been advanced in the trench and the joint has been inspected for movement.

The upstream end of the pipe shall be plugged at all times when pipe laying is not in progress. Water and dirt shall be prevented from entering the pipe.

4. Special Requirements for Main Sewers.

Tee branches for building sewers shall be installed at the locations shown on the drawings or as directed by the Engineer. The tee branches shall be installed with the main sewer pipe.

5. Special Requirements for Building Sewers.

Building sewers shall be 4-inch diameter Schedule 40 or SDR-21 PVC with gasketed connections, unless otherwise shown and shall be laid at a grade of ¼ inch per foot. A riser shall be installed if necessary, so that the building sewer can be laid at a grade of ¼ inch per foot to meet the required end elevation.

Concrete cradle, bend, end cap, and marker shall be installed for each building sewer before backfilling the main sewer pipe. If risers are to be used, they shall also be installed with these fittings.

Building sewer extensions shall be made as required after the main sewer has been completed or may be installed immediately after installation of the main sewer.

Whenever the end of a building sewer is to be backfilled, whether temporarily or permanently, a removable plug or end cap shall be installed. The plug or end cap shall be braced with removable blocking to prevent movement during testing. A 2" x 2" wood marker shall be placed at the end of all building sewers.

6. Repairs.

If it is necessary to repair or relay a section of pipe due to broken pipe, faulty line or grade, or any other reason, repair clamps shall not be used, but the pipe to be repaired shall be removed and replaced with new pipe; unless otherwise approved by the Town Engineer.

3.6.3 INSTALLATION OF MANHOLES.

1. Handling and Setting Manholes.

Precast manhole sections shall not be shipped or handled until concrete is completely cured. Any damage that occurs during shipping or handling shall be cause for rejection. Precast sections shall be inspected before unloading and any sections that have been damaged or do not meet the specifications shall not be unloaded.

Set the manholes on concrete cradle as detailed. All pipe openings shall be preformed as detailed.

2. Openings and Joints.

Openings around pipes and lift holes shall be completely filled with nonshrink grout and after initial set waterproofed on the outside with two coats of dampproofing. Riser, top, and grade ring joints shall be made using nonshrink grout in a sufficient quantity to cover the joint approximately ¼ inch thick for a strip 4 inches wide all around the outside of the manhole and waterproofed by covering with two coats of dampproofing. All joints and openings shall be closed upon setting the manhole.

3. Benches and Inverts.

Benches and inverts shall be formed of concrete and accurately shaped to a semicircular section conforming to the inside of the adjacent sewer pipe. Change in size and grade shall be made

gradually and evenly. Changes in direction of the sewer and entering branches shall have a radius $\frac{1}{2}$ the inside diameter of the manhole. Inverts for straight through manholes shall be constructed by laying the pipe through the manhole and then removing the upper half of the pipe. Benches shall be constructed of concrete and sloped to drain.

4. Grade Rings and Covers.

Grade rings shall be used to bring the manhole cover and frame to an elevation $\frac{1}{4}$ inch below finished grade in paved areas and to meet finished grade in other areas. Total height of grade rings shall not exceed 8 inches.

3.6.4 PREPARATION OF SEWER SYSTEM FOR USE.

1. General.

Provide all labor and equipment for cleaning and testing including hoses, pumps, plugs, temporary connections, gauges, meters and measuring devices to perform the specified tests. Testing shall be done under observation of the Town Engineer.

2. Water Supply for Testing.

The Contractor shall make arrangements for furnishing and disposing of water for testing.

3. Cleaning and Flushing.

Each section of sanitary sewer shall be flushed to remove all silt, sand, gravel, and other debris prior to testing. Hydraulic propelled devices, rodding equipment or machines for direct removal shall be used if any sections of pipe cannot be flushed clean.

Flushing shall be started at the highest end and proceed to the lowest end of the system. All debris shall be removed at each consecutive manhole and shall not be flushed into downstream sections.

4. Testing Requirements.

All sewers and manholes shall be tested for exfiltration and infiltration. Exfiltration testing of sewers shall be done by the use of compressed air. Manholes shall be tested for infiltration by vacuum testing.

Any section of sewer and any manhole that does not meet the specified test results must be repaired and retested until a satisfactory test is completed.

5. Air Testing.

Building sewers shall be tested with the main sewer and the following procedure shall be used:

- a. The test shall be conducted between two (2) consecutive manholes.
- b. The test section of the sewer line shall be plugged at each end. One of the plugs used at the manhole must be tapped and equipped with air inlet connection for filling the line from the air compressor.
- c. Ends of building sewers, cleanouts, stubs and fittings into the sewer test section shall be properly capped or plugged, and carefully braced against the internal pressure to prevent air leakage.
- d. An air hose shall be connected to tapped plug from the portable air control equipment which shall include valves and pressure gauges to control the air entry rate, and to monitor the air pressure in the pipeline.
- e. A second air hose shall be connected between the air compressor and the air control equipment.
- f. Supply air to the test section slowly, filling the pipeline until a constant pressure of 3.5 psig is maintained. The air pressure shall be regulated to prevent the pressure inside the pipe from exceeding 5.0 psig.
- g. When constant pressure of 3.5 psig is reached, throttle the air supply to maintain the internal pressure above 3.0 psig for at least five minutes. This time permits the temperature of the entering air to equalize with the temperature of the pipe wall.
- h. After the stabilization period, the air pressure shall be adjusted to 3.5 psig and the air supply disconnected. Observe the gauge until the air pressure reaches 3.0 psig. At 3.0 psig, commence timing with a stop watch which is allowed to run until the line pressure drops to 2.5 psig, at which time the stop watch shall be stopped. The time required, as shown on the stop watch, for a pressure loss of 0.5 psig shall not be less than the time shown in the following table:

<u>Pipe Diameter</u>	<u>Minutes</u>
42.0	
6	3.0
8	4.0
10	5.0
12	5.5
15	7.5
18	8.5
21	10.0
24	11.5

- i. A test air pressure correction shall be required when the prevailing groundwater is above the sewer line being tested. Under this condition, the air test pressure shall be increased to 0.433 psig for each foot the groundwater level is above the invert of the pipe.

- j. When building sewers are tested with the main sewers, the time requirement shall be determined by averaging the time for each diameter in proportion to the length of each size of pipe tested.
- k. If the length of the sewer being tested is less than 200 feet, an adjustment shall be made for the length and diameter of pipe in determining the allowable length of time for the loss of air at the average rate of 0.0011 cubic feet per minute per square foot of internal pipe surface under test from 3.0 psig to 2.5 psig.

6. Infiltration Testing.

A satisfactory infiltration test will be required for all sections of sanitary sewers before final acceptance of the system. The infiltration test shall include main sewers, building sewers and manholes, and the following procedure shall be used.

- a. The test shall be conducted in the downstream manhole.
- b. Any leaks into manholes shall be repaired prior to conducting the test.
- c. Place a V-notch weir into the upstream pipe in the manhole. The weir shall be installed so as to maintain a watertight seal between the weir and the interior surface of the pipe to prevent water by-passing the V-notch weir.
- d. V-notch weirs shall be commercially manufactured specifically for infiltration testing of sewers. All weirs used for testing shall be approved by the Engineer.
- e. After the V-notch weir has been installed, allow 24 hours for the infiltrating water to build-up and level off behind the weir, and thus permit a steady, uniform flow to pass over the V-notch weir.
- f. Measurements shall be taken after steady flow occurs over the V-notch weir. Leakage is determined from the readings, either directly or by converting the readings of the flow into terms of gallons per inch of pipe diameter per mile per day.
- g. Infiltration rates exceeding 100 gallons per day per inch of sewer diameter per mile shall be cause for rejection.

7. Vacuum Testing for Manholes.

A satisfactory infiltration test will be required for all sections of sanitary sewer manholes before final acceptance of the system. This test method is only applicable to precast concrete manholes. The following procedure shall be used.

- a. Any leaks into manholes shall be repaired prior to conducting the test.
- b. All lifting holes and exterior joints shall be filled with an approved non-shrink mortar grout.
- c. No grout will be placed in the horizontal joints before testing.
- d. All pipes entering the manhole shall be plugged, taking care to securely brace the plugs from being drawn into the manhole.
- e. The test head shall be placed at the inside of the top of the cone section and the seal inflated in accordance with the manufacturer's recommendations.
- f. A vacuum of 10 inches of mercury shall be drawn and the vacuum pump shut off. With the valves closed, the time shall be measured for the vacuum to drop to 9 inches.
- g. Acceptance for 4' diameter manholes shall be defined as when the time to drop to 9" of mercury meets or exceeds the following.

<u>Manhole Depth</u>	<u>Diameter</u>	<u>Time to Drop 1" Hg</u>
10' or less	4'	60 Seconds
10' to 15'	4'	75 Seconds
15' to 25'	4'	90 Seconds

For manholes 5' in diameter, add an additional 15 seconds, and for manholes 6' in diameter, add an additional 30 seconds to the time requirements listed in the above table. Conduct all "final" tests in the presence of the Engineer, and in accordance with ASTM Standards. Engineer shall be notified 24 hours in advance.

- h. Make all repairs which may be required to achieve acceptable test results at no additional cost to the Owner. Such repairs include all excavation, backfill and clean-up, in the event testing is delayed until after backfill has been placed.
8. Deflection Testing.

Deflection tests shall be performed on all flexible pipe. The test shall be conducted after the final backfill has been in place at least 30 days. No pipe shall exceed a deflection of 5%. If the deflection test is to use a rigid ball or mandrel, it shall have a diameter equal to 95% of the inside diameter of the pipe. The test shall be performed without mechanical pulling devices.

9. Alignment Testing (Lamp Test).

The test shall be conducted after the final backfill has been in place at least 30 days. After testing, the Engineer will make a complete visual inspection of the system. The Contractor shall remove and replace

manhole covers and furnish lights to assist the Engineer in making this inspection. The visual inspection (lamp test) is to verify that the pipes are straight and true in line and grade and to verify that settlement has not occurred. A full-unobstructed view shall be visible from manhole to manhole. The Contractor shall promptly repair all defects.

3.7. STORM DRAINAGE SYSTEM

3.7.1. MATERIALS FOR STORM DRAINAGE SYSTEM.

1. Storm Sewers.

NYSDOT 706-02, Reinforced Concrete Pipe Class IVP, Wall B Minimum, ball and spigot type joints with elastomeric gaskets.

Smooth interior corrugated high-density polyethylene pipe meeting: AASHTO M294 and ASTM D3350. Manning's "n" value for use in design shall not exceed 0.012.

2. Culverts.

Culverts with less than 12" of cover shall be NYSDOT 707-02, Corrugated Steel Pipe, Class II or IV, 14 gauge minimum thickness, galvanized, fully asphalt coated, with corrugated steel connecting bands.

Culverts with 12 or more inches of cover shall be either NYSDOT 707-02, Corrugated Steel Pipe, Class II or IV, 14 gauge minimum thickness, galvanized, fully asphalt coated, with corrugated steel connecting bands or smooth interior corrugated high density polyethylene pipe meeting: AASHTO M294 and ASTM D3350.

3. Concrete.

NYSDOT 501-2, Portland Cement Concrete, Class A, conforming to NYSDOT 501-1, 501-2, and 501-3.

4. Reinforcing Steel.

ASTM A-615, Grade 60 deformed reinforcing steel.

5. Nonshrink Grout.

Nonshrink, high strength, non-metallic, water resistant, pre-mixed grout. Octocrete as manufactured by Penncrete Products Company, or equal.

6. Concrete Curing Compound.

ASTM C-309 liquid membrane-forming compound for curing concrete.

7. Concrete Cradle.

NYSDOT 501-2, Portland Cement Concrete, Class B, 2-inch maximum slump.

8. Storm Laterals and Cleanouts.

Lateral shall be 6-inch diameter SDR-35 PVC.

9. Manholes.

a. Bases, Risers, and Cone Tops.

Precast reinforced concrete manhole units conforming to NYSDOT 706-04 requirements for circular manhole units and ASTM C-478. Refer to Standard Details for dimensions, minimum base slab reinforcing steel and other features.

b. Cover Slabs.

Precast reinforced concrete cover slabs. NYSDOT 555-2, Structural Concrete, Class A conforming to NYSDOT 501-1, 501-2 and 501-3, and ASTM A-615, Grade 60 deformed reinforcing steel. Refer to Standard Details for cover slab dimensions, reinforcing steel and other features.

c. Base, riser, and Cover Slab Joints.

Tongue and groove joints set in fast setting, nonshrink, high strength, water resistant, nonmetallic, premixed grout.

Continuous solid rubber ring gasketed joints conforming with ASTM C-443 will be considered by the Town Engineer in lieu of the nonshrink grout joints.

d. Manhole Steps.

Manhole steps shall be ½" grade 60 steel with copolymer polypropylene plastic covering, model PS2-PF as manufactured by M.A. Industries.

e. Dampproofing.

Manholes shall receive two 3.6 wet mil coats of tar base paint on interior and exterior. Bitumastic Black solution as manufactured by Koppers Company or DeGraco 9329 Standard Black as manufactured by the Detroit Graphite Company, or equal.

f. Manhole Frames and Covers.

Castings shall be uniform quality and shall be free from blowholes, porosity, hard spots, shrinkage defects, cracks, fins, burrs, sand and slag. Castings shall be cleaned by sand blasting and shall be asphalt coated by the manufacturer. Materials shall conform to ASTM A-48, Class 30.

Castings shall be true to pattern with satisfactory fit of component parts. Bearing surfaces shall be ground or

machined. Castings shall be designed to carry a wheel load of 16,000 pounds plus impact.

Total weight of frame and cover shall be 350 pounds.

Standard manhole frame and cover, Catalog No. 1032 indented top design and words "STORM SEWER" as manufactured by Syracuse Castings Sales Corporation, or equal.

g. Manhole Grates.

Standard manhole frame and grates, Catalog No. 1182 as manufactured by Syracuse Castings Sales Corporation, or equal.

h. Grade Rings.

ASTM C-478 precast reinforced concrete rings, 2 inches thick, 8 inches wide, and 24 inches I.D.

i. Brick.

ASTM C-32 sewer and manhole clay or shale brick.

10. Inlets.

a. Precast Concrete.

Precast concrete drainage units shall be in accordance with NYS DOT 706-04.

b. Mortar.

ASTM C-270, Type M. Mix design by volume shall be one part Portland Cement, one part masonry cement, and five parts mortar sand. Lime shall not be used.

c. Inlet Frame and Grate.

Inlet Frame and Grate shall be rectangular NYS DOT #9 meeting NYSDOT 655-2.02. Rectangular steel welded grates and frames, shall be galvanized and supplied with locking devices.

3.7.2. INSTALLATION OF STORM SEWERS.

1. Alignment and Grade.

Pipe installation shall commence at the lowest point with pipe bells laid on the upstream end. Pipe shall be installed at the elevation and grades shown on the drawings and with straight alignment between manholes and inlets.

2. Preparation of Pipe Bed.

The pipe bed shall consist of crushed stone and be prepared using hand tools to shape the bottom of the trench to match the barrel of the pipe with recesses for the joints. The pipe bed shall provide as nearly as possible a uniform and continuous bearing for the full length of the pipe between joints. Tolerances up to $\frac{1}{4}$ inch \pm variance in the pipe bed will be permitted.

Except where excavation for rock or unsuitable foundation material is required, care shall be taken not to excavate below the depth necessary to lay the pipe. If excavation does exceed the necessary depth, the trench shall be backfilled under the pipe with crushed stone and thoroughly tamped.

Where rock is encountered, it shall be removed to a depth six inches below the bottom of the pipe. Support the pipe on crushed stone cradle.

Where wet or unsuitable foundation material is encountered, it shall be removed. Support the pipe on crushed stone cradle.

The Contractor shall inspect pipe for damages before unloading. The pipe shall be unloaded with care to avoid damage. Pipe shall not be dropped or bumped against pipe already on the ground or any other object. Keep the pipe ends and interior clean.

Pipe shall be fully bedded in crushed stone in accordance with the Town of Parma Standard Details.

3. Making Joints.

Joints shall be made in accordance with the manufacturer's instructions and as directed by the engineer. The coupling or bell already in place shall be cleaned, the gasket inserted in the groove, lubricant applied, and the pipe or fitting carefully pushed into position. A gauge shall then be used to verify that the rubber ring is located in the groove all the way around and is at the proper depth in the joint. Joints shall not be made under water.

4. Installation of Pipe.

Each length of pipe shall rest on the prepared pipe bed or cradle for the full length of the barrel. The pipe shall be laid true to established line and grade to within $\frac{1}{4}$ inch. Any pipe that is disturbed after installation shall be taken up and re-laid.

If a trench shield is used, the pipe joint shall not be covered until after the shield has been advanced in the trench and the joint has been inspected for movement.

5. Repairs.

If it is necessary to repair or relay a section of pipe due to broken pipe, faulty line or grade, or any other reason, repair clamps shall not

be used, but the pipe to be repaired shall be removed and replaced with new pipe.

3.7.3. INSTALLATION OF MANHOLES.

1. Handling and Setting Manholes.

Precast manhole sections shall not be shipped or handled until concrete is completely cured. Any damage that occurs during shipping or handling shall be cause for rejection. Precast sections shall be inspected before unloading and any sections that have been damaged or do not meet the specifications shall not be unloaded.

Set the manholes on crushed cradle as detailed. All pipe openings shall be preformed as detailed.

2. Openings and Joints.

Openings around pipes and lift holes shall be completely filled with nonshrink grout and after initial set waterproofed on the outside with two coats of dampproofing. Riser, top, and grade ring joints shall be made using nonshrink grout in a sufficient quantity to fill the joint completely and to cover the joint approximately $\frac{1}{4}$ inch thick for a strip 4 inches wide all around the outside of the manhole and waterproofed by covering with two coats of dampproofing. All joints and openings shall be closed immediately upon setting the manhole.

3. Benches and Inverts.

Benches and inverts shall be formed of concrete and accurately shaped to a semicircular section conforming to the inside of the adjacent sewer pipe. Change in size and grade shall be made gradually and evenly. Changes in direction of the sewer and entering branches shall have a radius $\frac{1}{2}$ the inside diameter of the manhole.

4. Grade Rings and Covers.

Grade rings shall be used to bring the manhole cover and frame to an elevation $\frac{1}{4}$ inch below finished grade in paved areas and to meet finished grade in other areas. Total height of grade rings shall not exceed 8 inches.

3.7.4. INSTALLATION OF INLETS.

Install precast concrete inlets in accordance with NYSDOT 604-3, and as shown in the Standard Details.

Openings around pipes shall be completely filled with non-shrink grout. Inverts and benches shall be formed of concrete and shaped to drain.

Frames and grates shall be set in full mortar beds.

3.7.5. PREPARATION FOR USE.

1. Cleaning.

All pipes and appurtenances shall be cleaned by flushing or mechanical methods to remove all foreign material. Water shall be furnished and disposed of by the Contractor.

2. Inspection.

After cleaning, the Engineer will make a complete visual inspection of the system. The Contractor shall remove and replace manhole covers and furnish lights to assist the Engineer in making this inspection. The visual inspection (lamp test) is to verify that the pipes are straight and true in line and grade and to verify that settlement has not occurred. A full-unobstructed view shall be visible from manhole to manhole. The Contractor shall promptly repair all defects.

3.8. ROADWAYS AND STREETS

3.8.1. MATERIALS.

1. Granular Fill.

NYSDOT 203-2.02C, Select Granular Fill except that all particles shall pass a 2-inch square sieve.

2. Foundation Course.

NYSDOT 304-2, Subbase Course, Type 4, gravel or crushed stone. NYSDOT 703-0201, No. 3 crushed stone.

3. Crushed Stone.

NYSDOT 703-0201, Crushed Stone, Size 1A for surface treatment, or size selected by Engineer.

4. Bituminous Material.

NYSDOT 702-3101, Asphalt Emulsion, Grade RS-2, or grade and type of material selected by Engineer and Contractor.

5. Asphalt Concrete.

NYSDOT 401-2, Bituminous Plant Mix, Type 1 Base, Type 3 Binder Course and Type 7F Top Course.

6. Concrete.

NYSDOT 501-2, Portland Cement Concrete conforming to NYSDOT 501-1, 501-2, and 501-3. Class and compressive strength as specified.

7. Granite Curbs.

NYSDOT 714.01, Granite Curb.

8. Sidewalks.

NYSDOT 608-2, Concrete Sidewalks, Class A. Minimum 4000 psi 28 day compressive strength.

9. Concrete Gutters.

NYSDOT 624-2.02, Conventionally Formed Concrete Gutters, Class A concrete, minimum 4000 psi 28 day compressive strength. NYSDOT 624-2.05, Machine Formed Concrete Gutters. Submit concrete mix design to Town Engineer for approval. Minimum 4000 psi 28-day compressive strength, air content 7%.

10. Joint Fillers.

NYSDOT 705-07, Premoulded Bituminous Joint Filler. NYSDOT 705-02, Asphalt Filler.

11. Curing Compound.

NYSDOT 711-05, Membrane Curing Compound.

12. Geotextile Stabilization.

Geotextile stabilization laid over good to moderate strength subgrades for separation and confinement of base materials and over moderate to poor subgrades for separation, confinement, and stabilization of base material shall meet AASHTO M288-96 Specifications for Stabilization and Separation - Class 3. Geotextile stabilization shall be Mirafi 500X or approved equal.

3.8.2. PREPARATION OF SUBGRADE.

Preparation of subgrade shall not be started until all underground utilities are installed, tested, and found acceptable by the Town.

After completion of all underground construction, grade the subgrade surface to the required cross-section and grade, and compact it to form a smooth surface free of ruts, depressions and mounds. The final subgrade surface shall not deviate more than 1 inch from the required grade and cross-section. Stakes shall be provided at intervals of not more than 50 feet to construction and verify correct grades. The Developer shall provide personnel and strings, levels and similar equipment to verify the grades to the Town.

The Contractor shall notify the Town Highway Superintendent, the Developer's Engineer and the Town Engineer when the subgrade is completed. The completed subgrade shall be proof-rolled with a roller of not less than 10 tons operating weight.

Remove any soft or saturated subgrade material, replace it with granular fill and compact in accordance with requirements for Compaction Section 3.4.5.

3.8.3. FOUNDATION COURSE.

Do not start placing foundation course material until the subgrade is proof-rolled and inspected and approved by the Town Highway Superintendent and

the Town Engineer. After approval place geotextile stabilization over subgrade, in accordance with NYSDOT 207-3.

Place, grade and compact the foundation course on completed subgrade surface to the alignment, grade and cross-section shown on the drawings. The subgrade surface shall be free of standing water, snow, ice and frozen material prior to placing the foundation course.

Construct the foundation course in accordance with NYSDOT 304-3. Compaction shall be in accordance with applicable requirements of NYSDOT 203-3.12, and shall provide not less than 95% of the maximum dry weight density of the material as determined by ASTM D698.

Construct the foundation course for roads and streets in lifts to a minimum total compacted thickness of as indicated on the Standard Detail. Construct the foundation course for sidewalks and gutters in a single lift to a minimum compacted thickness of 6 inches.

Adjust all manhole and drop inlet frames and covers, valve boxes, and other appurtenances to conform to finished grades.

3.8.4. PAVEMENT CONSTRUCTION.

1. General.

After completion of the foundation course and only after inspection and approval by the Town Highway Superintendent and the Town Engineer, construct pavements to alignment, grade and cross-section shown on the drawings. The foundation course shall be free of standing water, snow, ice and frozen material prior to and during pavement construction.

The finished pavement surface shall be dense, smooth, free of ruts, ridges, roller marks, cracks, depressions or other irregularities. Any defective pavement that cannot be corrected by additional rolling, shall be removed and replaced with new pavement.

The type of pavement shall be as shown on the drawings and on typical sections.

Placement of asphalt shall be in accordance with NYSDOT 402-3.07 80 Series, Option A or B, as directed by the Town Engineer or Highway Superintendent

2. Asphalt Concrete Base.

Asphalt base shall be Type 1 meet the requirements of NYS DOT 401-2 shall be constructed to a minimum compacted thickness of five (5) inches, or greater thickness shown on the drawings, in accordance with applicable requirements of NYSDOT 401-3.

3. Asphalt Concrete Binder.

Binder shall be constructed to a minimum compacted thickness of three (3) inches, or greater thickness shown on the drawings, in accordance with applicable requirements of NYSDOT 401-3.

4. Asphalt Concrete Top.

Before placing of the top course, the binder course shall have gone through one winter season of freeze thaw cycle and 75% of the building units are completed. Also prior to placement of the top course, the binder shall be cleaned of mud, dust and debris, and shall be inspected by the Town Highway Superintendent and the Town Engineer. The Highway Superintendent and the Town Engineer may require application of a tack coat at a rate of 0.1 gallon per square yard before placing the top course. Any depressions or settlements in the binder shall be repaired by shimming before placing the top course.

Top course shall be constructed to a minimum compacted thickness of one (1) inch, or greater thickness shown on the drawings, in accordance with applicable requirements on NYSDOT 401-3.

3.8.5. CONCRETE GUTTERS.

1. General.

Concrete gutters shall be constructed using conventional steel forms or machine forming.

Before setting forms, the foundation course shall be inspected by the Town Superintendent and the Town Engineer. Any ruts, depressions and soft areas shall be corrected and the surface regraded and thoroughly compacted. The foundation course shall be thoroughly wetted before placing concrete.

Construct concrete gutters where indicated on the drawings in accordance with the Standard Details and NYSDOT 624-3.02.

2. Casting Segments.

Conventionally formed gutters shall be cast in minimum of 8-foot segments. An 1/8-inch thick separator plate cut to fit the section shall be used in each joint and removed as the concrete hardens, or the gutter may be constructed in alternate sections, 24 hours to elapse before construction of adjacent sections. Construction joints shall be poured full with Asphalt Filler.

3. Conventional Forms.

Forms shall be steel, straight, free from warp, and constructed not to interfere with inspection for grade or alignment. All forms shall extend for the full gutter depth and shall be braced and secured to prevent displacement from alignment during placing of concrete.

4. Concrete Placing and Finishing.

Concrete shall be placed in conventional forms in accordance with the applicable requirements of NYSDOT 555-3.04. Excess concrete shall be screeded off perpendicular to the flow line of the gutter. Forms shall be left in place for 24 hours or until the concrete has sufficiently

hardened, as determined by the Engineer, so that they can be removed without damage to the gutter.

The gutters shall be finished to produce a smooth surface and then lightly broomed to a uniform texture.

5. Machine Forming.

Gutter shall be machine formed to the proper line and grade. The Engineer may require the Contractor to demonstrate that the specific equipment he proposed to use is capable of satisfactorily placing the concrete mix.

Any gutter placed outside of tolerance of 1/2 inch of the established line or 1/4 inch of the established grade shall be removed and replaced at the Contractor's expense.

Maximum placement slump shall be 2 1/2". Air content shall be within +1% of design.

6. Contraction Joints.

Contraction joints for machine formed gutter shall be spaced every 8 feet and formed or sawcut 1/8" wide and 3/4" deep. The sawcut or formed joints shall be left unfilled.

7. Expansion Joints.

Expansion joints for conventionally formed and machine formed gutter shall be 1/2-inch wide and shall be formed with joint filler, placed at intervals not to exceed 50 feet. The filler material shall be cut to conform to the cross-section of the gutter and shall extend the full width and depth of the gutter.

8. Concrete Curing.

Curing shall comply with the requirements of NYSDOT 502-3.10, Curing. Curing compound shall be applied by spraying in accordance with manufacturer's instructions upon initial setting of the concrete.

9. Protection.

The Contractor shall keep the gutter clean, aligned, and protected from damage until final acceptance of the work.

Any gutter damaged prior to the final acceptance of the work shall be repaired or replaced at the Contractor's expense.

3.8.6. CURBS.

1. Granite Curbs

Granite curbs, including base course, concrete backing and mortar joints shall be installed in accordance with NYSDOT 609-3.01 and in accordance with the Standard Details.

2. Concrete Curbs

Concrete curbs, including base course shall be installed in accordance with NYSDOT 609-3 and in accordance with the Standard Details.

3.8.7. CONCRETE SIDEWALKS.

1. General.

Before setting forms, the foundation course shall be inspected by the Town Highway Superintendent and the Town Engineer. Any depressions, ruts and soft areas shall be corrected and the surface regraded and thoroughly compacted. The foundation course shall be thoroughly wetted before placing of concrete.

Construct concrete sidewalks where shown on the drawings in accordance with the Standards Details and NYSDOT 608-3.01.

2. Forms.

Forms shall be steel, straight, free from warp and constructed not to interfere with screeding of concrete. Wood forms may be used only for curved sections. All forms shall extend the full 5-inch depth of the sidewalk and shall be braced and secured to prevent displacement of alignment during placing of concrete.

3. Concrete Placing and Finishing.

Concrete shall be placed to the full depth shown on the drawings and in the Standard Details.

Transverse expansion joints shall extend to the full depth of the slab and shall be spaced maximum of 25 feet apart. The edges of joints shall be finished with an edging tool having a ¼-inch radius.

A premolded bituminous joint filler ½-inch thick shall be installed at all: construction joints, expansion joints and joints between sidewalk and curbs, pavements, gutters and buildings.

The concrete surface shall be scored at intervals of five feet so that the finished walk will be marked in squares. The concrete shall be finished to produce a smooth surface and then lightly broomed to a uniform texture.

4. Curing.

Curing shall comply with the requirements of NYSDOT 502-3.10. Curing compound shall be applied by spraying in accordance with manufacturer's instructions upon initial setting of the concrete.

5. Protection.

The Contractor shall keep the sidewalk clean and protected from damage until final acceptance of the work. Any sidewalk damaged

prior to the final acceptance of the work shall be repaired or replaced at the Contractor's expense.

3.8.8. DRIVEWAYS

1. Residential driveways within the Town right-of-way shall be paved as follows: 2" asphalt binder and 1" asphalt top or 5" 4,000 PSI concrete.
2. Commercial driveways within the Town right-of-way shall be paved as follows: 3" asphalt binder and 1" asphalt top or 6" 4,000 PSI concrete.

3.8.9. STREET AND TRAFFIC SIGNS.

1. Street Signs.

Street signs shall be provided at all street intersections, shall be of the type approved by the Town Highway Superintendent, and shall conform to the requirement of NYS Manual of Uniform Traffic Control Devices.

2. Traffic Signs.

Traffic signs shall be provided at intersections designated by the Town Highway Superintendent and shall conform to the requirements of NYS Manual of Uniform Traffic Control Devices.

3.8.10. MONUMENTS.

Monuments shall be 8-inch diameter or square precast concrete 48 inches long, with a 1/2-inch steel reinforcing rod embedded in the center. The top of the rod shall serve as the point of reference.

Monuments shall be installed plumb, with the top set 1/4-inch below finished grade, at the locations shown on the approved final plans and staked out by a Licensed Surveyor. Fill the space around the monument with thoroughly compacted dry concrete.

3.8.11. PROPERTY CORNER MARKERS.

During construction lots may be staked with wood hubs. After construction and final grading is completed, permanent corner markers consisting of 3/4-inch diameter solid steel rod 24-inches long, shall be set by a Licensed Surveyor at all corners of each lot.

The top of the rod shall be set 1/4-inch below finished grade.

3.9. STREET LIGHTING

3.9.1. GENERAL.

Street lighting consists of furnishing and installing a complete lighting system including pole bases, poles, luminaries, lamps, photoelectric controls, electrical conductors, fittings, and related work required to operate

and control the street lighting system, and shall conform to the applicable requirements of NYSDOT 670.

All electrical work shall conform to the National Electrical Code (NEC) of the latest revision, and to the regulations of the utility company which supplies service to the installation.

Upon completion of the Work, provide a certificate of inspection and approval of the electrical system by a third party inspection agency recognized and acceptable to the Town.

3.9.2. MATERIALS.

1. Luminaires.

McGraw Edison TRD-3283-120-R-V-BK-TA1BK light fixture complete with turn-lock self-contained street lighting photo-electric control with surge protection, 150 watt HPS lamp, and ladder rest. Provide inline fuses and disconnect for each luminaire.

2. Light Standards.

High-line HL-117-S-20-T-03-AA-D, or Shakespeare BS-17-01-N1-BO-08; direct bury fiberglass pole.

High-line HL-114-20-S-03-AA-B, or Shakespeare AS-14-01-N1-BB; anchor base fiberglass pole.

3. Foundations for Light Standards.

Precast foundations for light standards including anchor bolts positioned in accordance with the template provided by the light standard manufacturer. Anchor base plates shall be one piece castings, and shall be provided with four anchor bolt covers.

4. Wire and Cable.

Wire and cable sized for the circuit ratings or application. No wire smaller than No. 12 AWG gauge shall be used except for low voltage circuits. Use type THW wire throughout.

5. Conduit and Fittings.

Galvanized heavy wall rigid conduit (GRC) bearing an Underwriter's Laboratories label. Couplings, connectors and fittings of the type and size specified by the NEC for each use.

6. Junction Boxes.

Cast iron box with cover, hot-dip galvanized finish with neoprene gasket and stainless steel cover screws. Catalog No. FF 161206, as manufactured by Spring City Electrical Manufacturing Company, or equal.

7. Pullboxes.

Precast concrete pullboxes with cast iron frames and grates, designed for the vehicular traffic requirements of the installation location.

3.9.3. INSTALLATION OF STREET LIGHTING.

1. General.

Street and parking lot lighting shall be installed in accordance with the regulations of the utility company providing service, and the Town requirements established for the area. Installation of street lighting within the right-of-way of State highways shall conform to NYSDOT requirements and these Specifications.

2. Photoelectrical Control.

Photoelectrical controls shall activate street lighting when natural lighting fall below one footcandle, and shall deactivate street lighting when natural lighting is above two and a half footcandles. In the event of component failure, the street lighting should be activated.

The photoelectric controls shall provide precise light level adjustment from outside of the luminaire, and be adjustable while the luminaire remains in service.

3. Light Standards.

Provide anchor base poles along streets and direct bury poles in parking lots and activity areas.

4. Foundations.

Excavation for precast foundations shall be performed in a manner to insure foundation stability after backfill. Provide one-foot minimum clearance between precast unit and sides of the excavation for concrete backfill, and three feet minimum clearance for select granular fill.

Backfill material for foundations placed in disturbed areas shall only be select granular fill.

5. Grounding and Testing.

All metal conduits, enclosures and neutral conductors shall be permanently grounded. Make all ground connections as required by the National Electrical Code.

All circuits and feeders shall be tested and proven free of improper grounds.

6. Conduit.

All underground wiring shall be installed in conduit and shall be installed with 24 inches minimum cover to finished grade. Provide conduit between pullboxes, junction boxes and to light standards.

7. Joints and Splices.

Joints and splice shall be made with compression connectors required for size and application of conductor. Joints and splices shall be made only at junction boxes and within terminal enclosures.

8. Excavation and Miscellaneous Work.

Excavation for conduit, junction boxes, pullboxes, and foundations shall conform to the applicable requirements of Section 3.3.

Excavation shall not proceed until the conduit, junction box, pullbox, or foundation is ready to be installed. Pavements and sidewalks removed during installation shall be repaired in accordance with the applicable requirements of Section 3.8. Remove and replace complete sidewalk panels.

Backfill and compaction for conduit, junction boxes, pullboxes, and foundations shall be in accordance with the applicable requirements of Section 3.4.

SECTION 4. STANDARD DETAILS

STANDARD DETAIL INDEX

DESCRIPTION	DETAIL NUMBER
Typical Utility Layout	G-1
Standard Plan Notes	G-2
Standard Monument Detail	G-3
Tree planting Detail	G-4
Tree Staking Detail	G-5
Standard Gutter Inlet Detail	S-1
Typical Storm and Sanitary Sewer Trench	S-2
Sanitary and Storm Manhole Detail	S-3
Standard Manhole Dimensions	S-4
Dog-house Manhole Detail	S-5
Outside Drop Connection	S-6
Inside Drop Connection	S-7
Sanitary and Storm Lateral Riser Detail	S-8
Water Main and Sewer Crossing Detail	S-9
Typical Field Inlet	S-10
Standard Minor Road Detail	H-1
Standard Collector Road Detail	H-2
Typical Parkway Road	H-3
Typical Private Road Section	H-4
Typical Cul-De-Sac Detail	H-5
Typical Cul-De-Sac with Landscape Island Detail	H-6
Typical Concrete Gutter	H-7
Typical Temporary Turnaround Detail	H-8
Typical Sidewalk Detail	H-9
Typical ADA Sidewalk Detectable Warnings	H-10
Standard Light Pole Detail	H-11
Typical Driveway with Gutter Detail	H-12
Typical Driveway with Culvert Detail	H-13

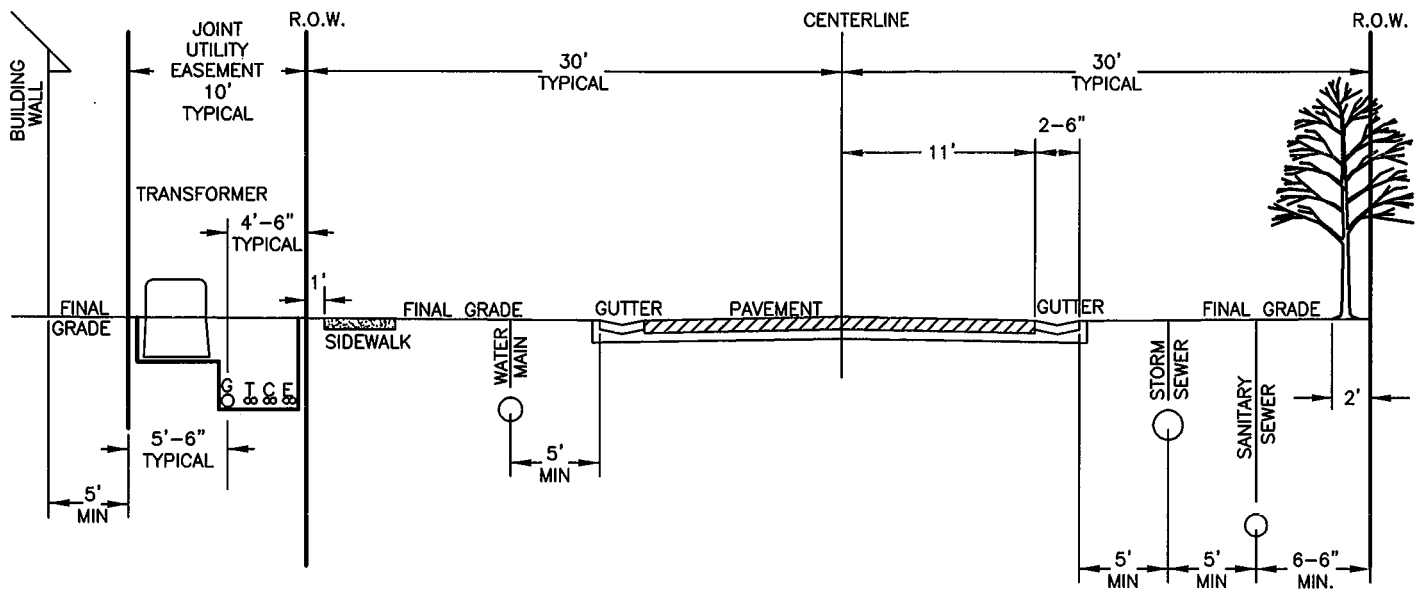

LEGEND:

- G - GAS
- C - CABLE
- T - TELEPHONE
- E - ELECTRIC

NOTE: ALL UTILITIES TO BE UNDERGROUND

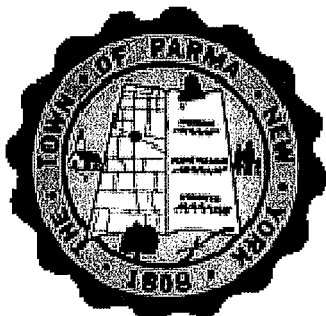

Standard Detail No. G-1
 Typical Utility Layout
 Scale: N.T.S.

Town of Parma
 Development Regulations

October 2013

1. ALL IMPROVEMENTS SHALL BE IN ACCORDANCE WITH THE MOST CURRENT DEVELOPMENT REGULATIONS FOR THE TOWN OF PARMA.
2. THE APPLICANT'S AND CONTRACTOR'S ATTENTION IS DIRECTED TO MONROE COUNTY LOCAL LAW #6 OF 1971, REGARDING LIABILITY INCURRED THROUGH DISTURBANCE OR DESTRUCTION OF GEODETIC SURVEY MONUMENTS.
3. THE CONTRACTOR SHALL DETERMINE THE EXACT LOCATION AND ELEVATION OF EXISTING UNDERGROUND UTILITIES PRIOR TO BEGINNING CONSTRUCTION. THE CONTRACTOR SHALL MAKE EXPLORATORY EXCAVATIONS TO LOCATE EXISTING UNDERGROUND UTILITIES SUFFICIENTLY AHEAD OF CONSTRUCTION TO ALLOW REVISIONS AS REQUIRED TO MEET EXISTING CONDITIONS.
4. NOTIFY DIG SAFELY NEW YORK TWO (2) WORKING DAYS PRIOR TO DIGGING, DRILLING OR BLASTING AT 1-800-962-7962 FOR A UTILITY STAKEOUT.
5. ANY SIGNIFICANT DEVIATIONS FROM THE APPROVED PLANS, AS DETERMINED BY THE BUILDING INSPECTOR, MUST BE RESUBMITTED TO THE PLANNING BOARD FOR RE-APPROVAL. A CHANGE IN HOUSE LOCATION NOT EXCEEDING 10 FEET FROM THE APPROVED PLAN, AND NOT IN VIOLATION OF ANY EXISTING CODE, AND NOT AFFECTING THE LEACH FIELD MAY BE APPROVED BY THE BUILDING INSPECTOR IN THE FIELD. OTHER CHANGES IN THE HOUSE AND/OR SEPTIC SYSTEM LOCATION MUST BE RESUBMITTED TO THE PLANNING BOARD FOR APPROVAL.
6. THE APPLICANT'S ENGINEER OR SURVEYOR SHALL SET LOT MONUMENTATION PINS AT ALL CORNERS AND ANGLES.
7. LOT LINE SWALES ARE TO BE CONSTRUCTED AND OPERABLE PRIOR TO THE ISSUANCE OF A CERTIFICATE OF OCCUPANCY.
8. DRIVEWAYS ARE TO BE PAVED WITHIN THE HIGHWAY OR STREET RIGHT-OF-WAY, AND A CULVERT PIPE OF A SIZE AND TYPE APPROVED BY THE HIGHWAY SUPERINTENDENT OR DESIGNEE IS TO BE PLACED BY THE DEVELOPER. TO PREVENT EROSION SUMP PUMPS AND ROOF LEADERS DISCHARGING TO ROADSIDE DITCHES SHALL BE PIPED.
9. THE CONTRACTOR SHALL PROVIDE FOR EROSION CONTROL BARRIERS DURING CONSTRUCTION AND REMOVAL OF THE SAME UPON REVEGETATION OF THE DISTURBED AREAS.
10. THE CONTRACTOR SHALL BE REQUIRED TO CLEAN MUD AND DEBRIS FROM PUBLIC ROADS SERVICING THE CONSTRUCTION SITE, DURING AND AFTER THE COMPLETION OF THE PROJECT.
11. THE CONTRACTOR SHALL NOT OPERATE TRACKED CONSTRUCTION EQUIPMENT ON DEDICATED ROADS. THE CONTRACTOR/DEVELOPER SHALL BE RESPONSIBLE FOR ALL SITE AND ROADWORK DAMAGED DURING CONSTRUCTION OPERATIONS AND SAID DAMAGE SHALL BE REPAIRED, AT THE DEVELOPER'S/CONTRACTOR'S EXPENSE, PRIOR TO ACCEPTANCE OF DEDICATION TO THE TOWN.
12. WHERE THE ONLY ACCESS TO THE PROJECT IS VIA AN EXISTING DEDICATED ROAD, THE CONTRACTOR/DEVELOPER SHALL REQUEST PERMISSION FROM THE TOWN BOARD TO USE THE ROAD AS A CONSTRUCTION ACCESS. A FINANCIAL GUARANTEE SHALL BE PROVIDED TO COVER DAMAGES TO THE ROAD DUE TO CONSTRUCTION EQUIPMENT.
13. WHEN ROAD CUTS ARE REQUIRED FOR INSTALLATION OF UTILITIES UNDER EXISTING DEDICATED ROADS, BACKFILL MATERIALS SHALL BE COMPACTED AND APPROVED BY THE TOWN ENGINEER PRIOR TO RESURFACING. BACKFILL MATERIALS AND COMPACTION METHODS SHALL BE APPROVED BY THE TOWN ENGINEER.
14. THE CONTRACTOR SHALL TAKE APPROPRIATE PRECAUTIONS TO PROTECT PROPERTY MARKERS AND ALL SURVEY STAKES.
15. SANITARY SEWER FACILITIES SHALL BE DESIGNED AND CONSTRUCTED IN ACCORDANCE WITH THE MONROE COUNTY HEALTH DEPARTMENT, MONROE COUNTY PURE WATERS, AND TOWN OF PARMA SEWER STANDARDS.
16. WATER SERVICES SHALL BE DESIGNED AND CONSTRUCTED IN ACCORDANCE WITH THE MONROE COUNTY WATER AUTHORITY STANDARDS. THE TOWN OF PARMA IS NOT RESPONSIBLE FOR THE QUANTITY OR QUALITY OF THE WATER.
17. FOUNDATION AND CELLAR DRAINAGE SHALL DISCHARGE TO STREET STORM DRAINAGE SYSTEMS, OR AS OTHERWISE APPROVED BY THE TOWN ENGINEER.
18. ALL UTILITIES ARE TO BE INSTALLED UNDERGROUND.
19. LOT GRADING AND FIRST FLOOR ELEVATIONS SHALL BE CERTIFIED, BY THE DEVELOPER'S OR BUILDER'S LICENSED SURVEYOR, AS TO CONFORMANCE TO THE APPROVED PLANS PRIOR TO ISSUANCE OF A CERTIFICATE OF OCCUPANCY
20. THE TOWN AND ITS AGENTS WILL NOT BE RESPONSIBLE FOR AND WILL NOT HAVE CHARGE OF CONSTRUCTION MEANS, METHODS, TECHNIQUES, SEQUENCES OR PROCEDURES, OR FOR SAFETY PRECAUTIONS AND PROGRAMS IN CONNECTION WITH THE WORK.



Standard Detail No. G-2
Standard Plan Notes
Scale: N.T.S.

Town of Parma
Development Regulations

October 2013

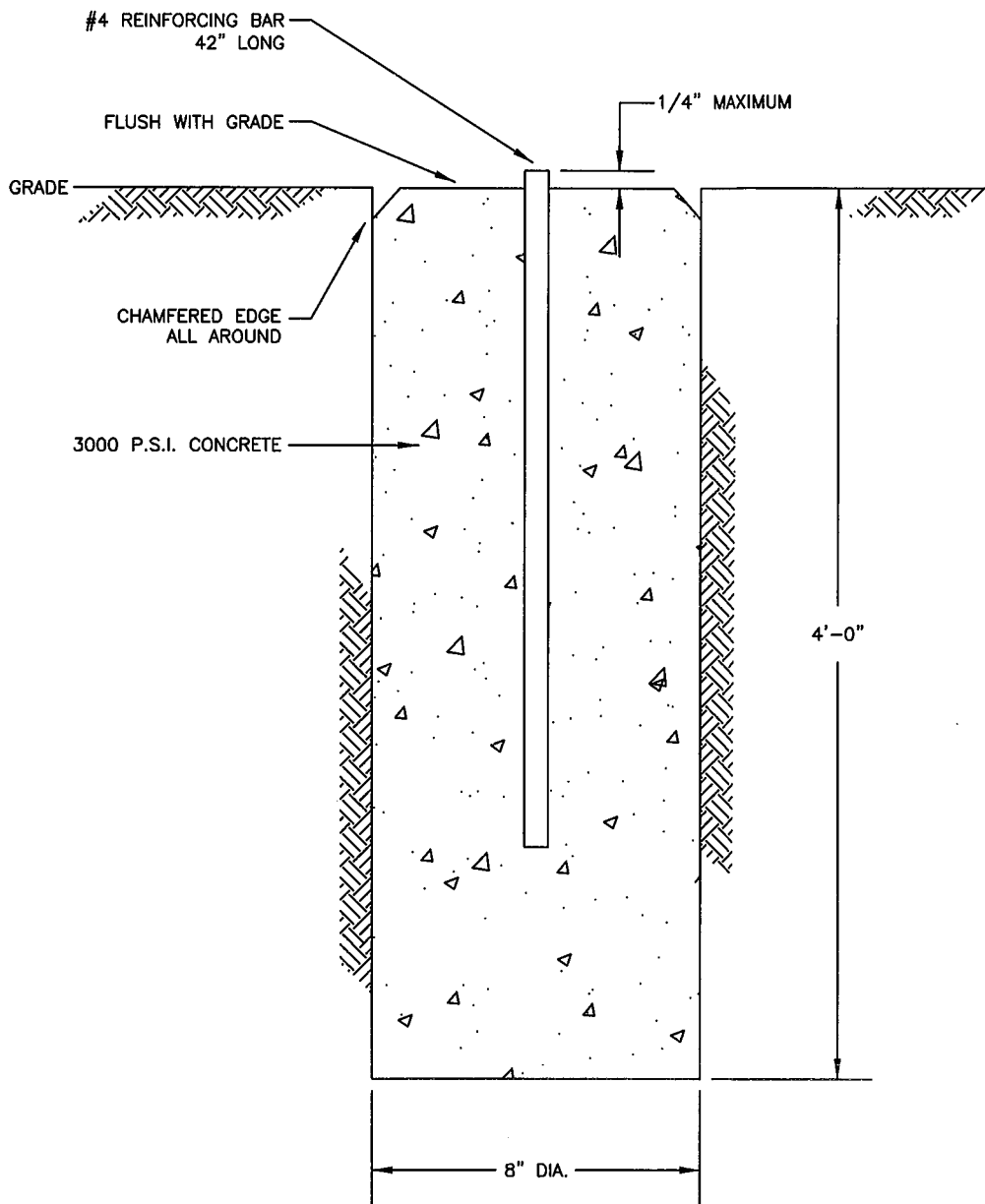

NOTES:

1. TO BE LOCATED ALONG R.O.W. AT POINTS OF CURVATURE.
2. MAXIMUM SPACING 600'

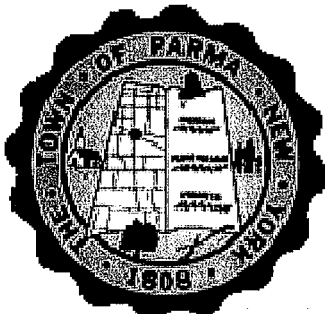

Standard Detail No. G-3
 Standard Monument Detail
 Scale: N.T.S.

Town of Parma
 Development Regulations

October 2013

DO NOT HEAVILY PRUNE THE TREE AT PLANTING. PRUNE ONLY CROSSOVER LIMBS, CO-DOMINANT LEADERS, AND BROKEN OR DEAD BRANCHES. SOME INTERIOR TWIGS AND LATERAL BRANCHES MAY BE PRUNED; HOWEVER, DO NOT REMOVE THE TERMINAL BUDS OF BRANCHES THAT EXTEND TO THE EDGE OF THE CROWN.

STAKE TREES ONLY UPON THE APPROVAL OF THE TOWN. SEE STAKING DETAIL.

WRAP TREE TRUNKS ONLY UPON THE APPROVAL OF THE TOWN. SEE WRAPPING DETAIL.

MARK THE NORTH SIDE OF THE TREE IN THE NURSERY, AND ROTATE TREE TO FACE NORTH AT THE SITE WHEN EVER POSSIBLE.

SET TOP OF ROOT BALL FLUSH TO GRADE OR 1-2 IN. HIGHER IN SLOWLY DRAINING SOILS.

50 MM (2 IN.) MULCH. DO NOT PLACE MULCH IN CONTACT WITH TREE TRUNK. MAINTAIN THE MULCH WEED-FREE FOR A MINIMUM OF THREE YEARS AFTER PLANTING.

SOIL IMPROVEMENTS/EXCAVATION AREA
2X ROOT BALL DIAMETER

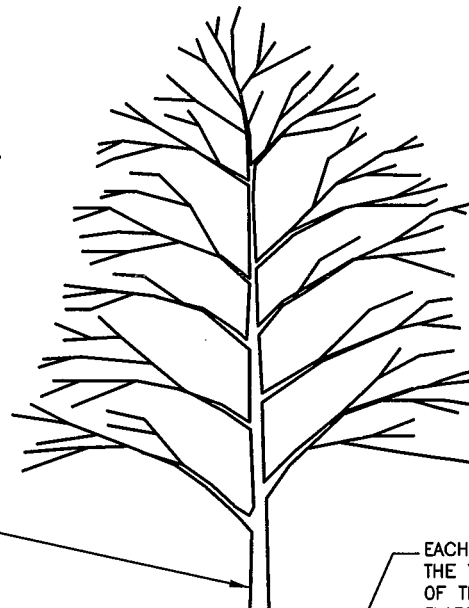

EACH TREE MUST BE PLANTED SUCH THAT THE TRUNK FLARE IS VISIBLE AT THE TOP OF THE ROOT BALL. TREES WHERE THE TRUNK FLARE IS NOT VISIBLE SHALL BE REJECTED. DO NOT COVER THE TOP OF THE ROOT BALL WITH SOIL.

MULCH RING
6 FT. DIAM. MIN.
8 FT. DIAM. PREFERRED

8 IN.

4 IN. HIGH EARTH SAUCER
BEYOND EDGE OF ROOT BALL.

REMOVE ALL TWINE, ROPE AND WIRE, AND BURLAP FROM TOP HALF OF ROOT BALL

IF PLANT IS SHIPPED WITH A WIRE BASKET AROUND THE ROOT BALL, CUT THE WIRE BASKET IN FOUR PLACES AND FOLD DOWN 8 IN. INTO PLANTING HOLE.

PLACE ROOT BALL ON UNEXCAVATED OR TAMPED SOIL.

TAMP SOIL AROUND ROOT BALL BASE FIRMLY WITH FOOT PRESSURE SO THAT ROOT BALL DOES NOT SHIFT.



Standard Detail No. G-4
Tree Planting Detail
Scale: N.T.S.

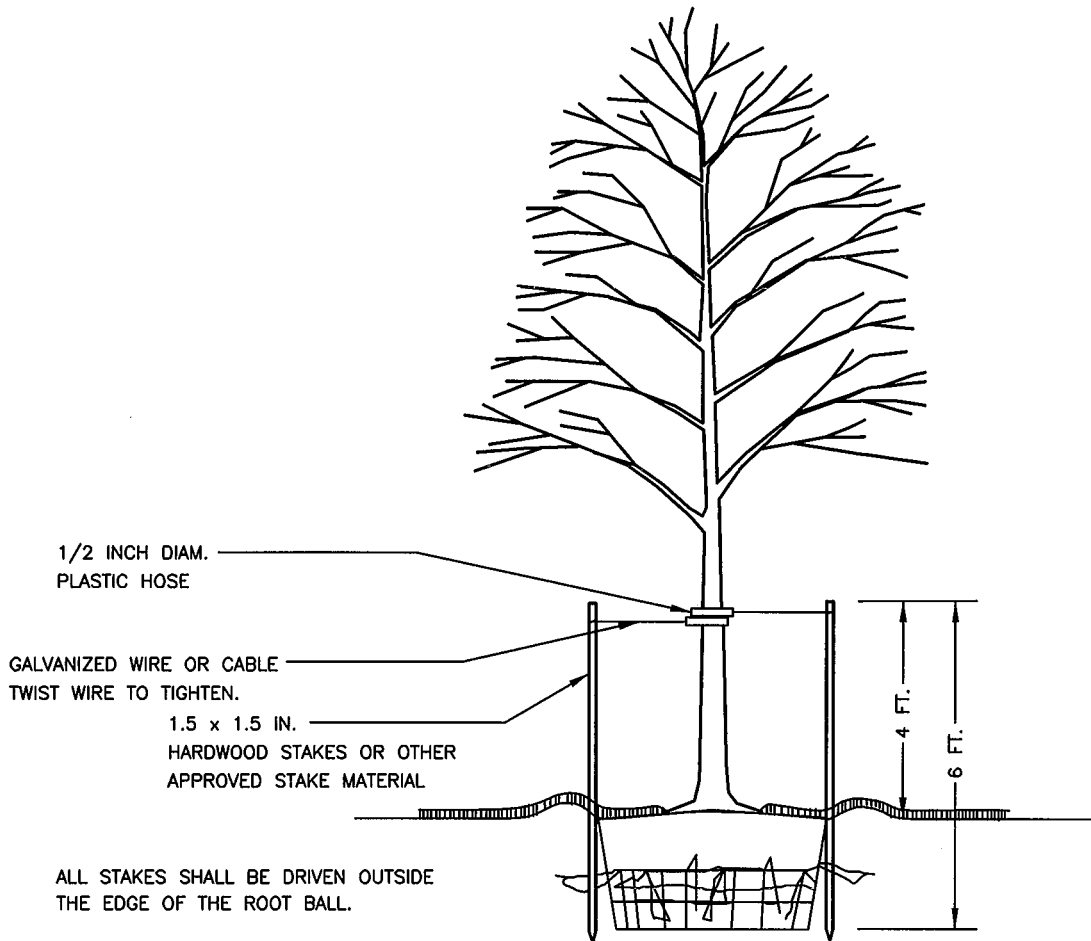

WIRE OR CABLE SIZES SHALL BE AS FOLLOWS:

TREES UP TO 65 MM (2.5 IN.) CALIPER - 14 GAUGE

TREES 65 MM (2.5 IN.) TO 75 MM (3 IN.) CALIPER - 12 GAUGE

TIGHTEN WIRE OR CABLE ONLY ENOUGH TO KEEP FROM SLIPPING. ALLOW FOR SOME TRUNK MOVEMENT. PLASTIC HOSE SHALL BE LONG ENOUGH TO ACCOMMODATE 35MM (1.5 IN.) OF GROWTH AND BUFFER ALL BRANCHES FROM THE WIRE.

TUCK ANY LOOSE ENDS OF THE WIRE OR CABLE INTO THE WIRE WRAP SO THAT NO SHARP WIRE ENDS ARE EXPOSED.

ASSURE THAT THE BEARING SURFACE OF THE PROTECTIVE COVERING OF THE WIRE OR CABLE AGAINST THE TREE TRUNK IS A MINIMUM OF 1/2 INCH.

REMOVE ALL STAKING AS SOON AS THE TREE HAS GROWN SUFFICIENT ROOTS TO OVERCOME THE PROBLEM THAT REQUIRED THE TREE TO BE STAKED. STAKES SHALL BE REMOVED NO LATER THE END OF THE FIRST GROWING SEASON AFTER PLANTING.

TREES NORMALLY DO NOT NEED TO BE STAKED AND STAKING CAN BE HARMFUL TO THE TREE. STAKING SHOULD BE DONE ONLY WITH THE APPROVAL OF THE LANDSCAPE ARCHITECT IF IT IS EXPECTED THAT THE TREE WILL NOT BE ABLE TO SUPPORT ITSELF. THE FOLLOWING ARE REASONS WHY TREES DO NOT REMAIN STRAIGHT.

- o TREES WITH POOR - QUALITY ROOT BALLS OR ROOT BALLS THAT HAVE BEEN CRACKED OR DAMAGED. REJECT RATHER THAN STAKE.
- o TREES THAT HAVE GROWN TOO CLOSE TOGETHER IN THE NURSERY, RESULTING IN WEAK TRUNKS. REJECT RATHER THAN STAKE.
- o PLANTING PROCEDURES THAT DO NOT ADEQUATELY TAMP SOILS AROUND THE ROOT BALL. CORRECT THE PLANTING PROCEDURE.
- o ROOT BALLS PLACED ON SOFT SOIL. TAMP SOILS UNDER ROOT BALL PRIOR TO PLANTING.
- o ROOT BALLS WITH VERY SANDY SOIL OR VERY WET CLAY SOIL. STAKING ADVISABLE.
- o TREES LOCATED IN A PLACE OF EXTREMELY WINDY CONDITIONS. STAKING ADVISABLE.

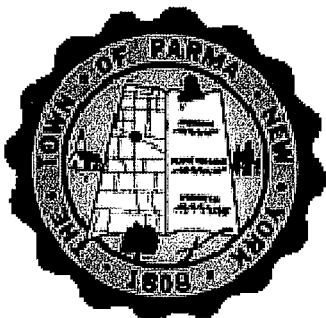

**Standard Detail No. G-5
Tree Staking Detail - 3 In. Caliper or Less
Scale: N.T.S.**

**Town of Parma
Development Regulations**

October 2013

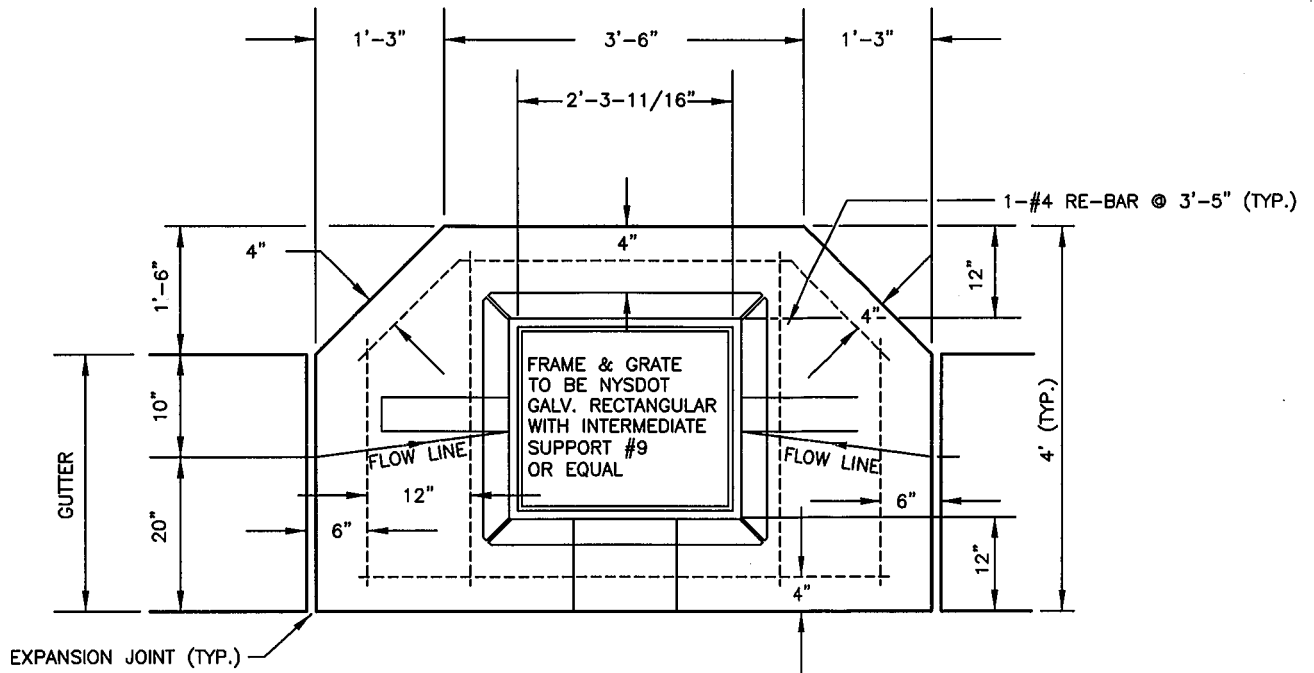

PLAN

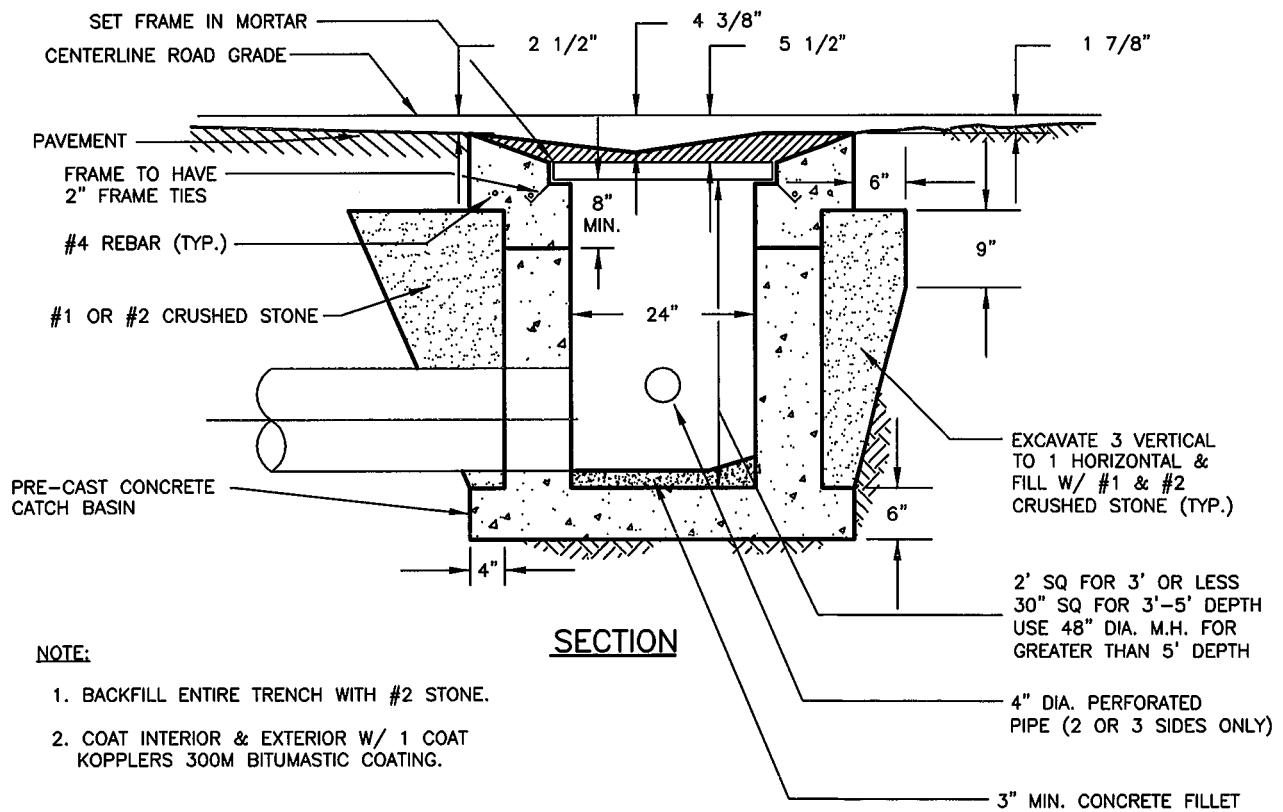

SECTION

NOTE:

1. BACKFILL ENTIRE TRENCH WITH #2 STONE.
2. COAT INTERIOR & EXTERIOR W/ 1 COAT KOPPLERS 300M BITUMASTIC COATING.



Standard Detail No. S-1
Standard Gutter Inlet Detail
Scale: N.T.S.

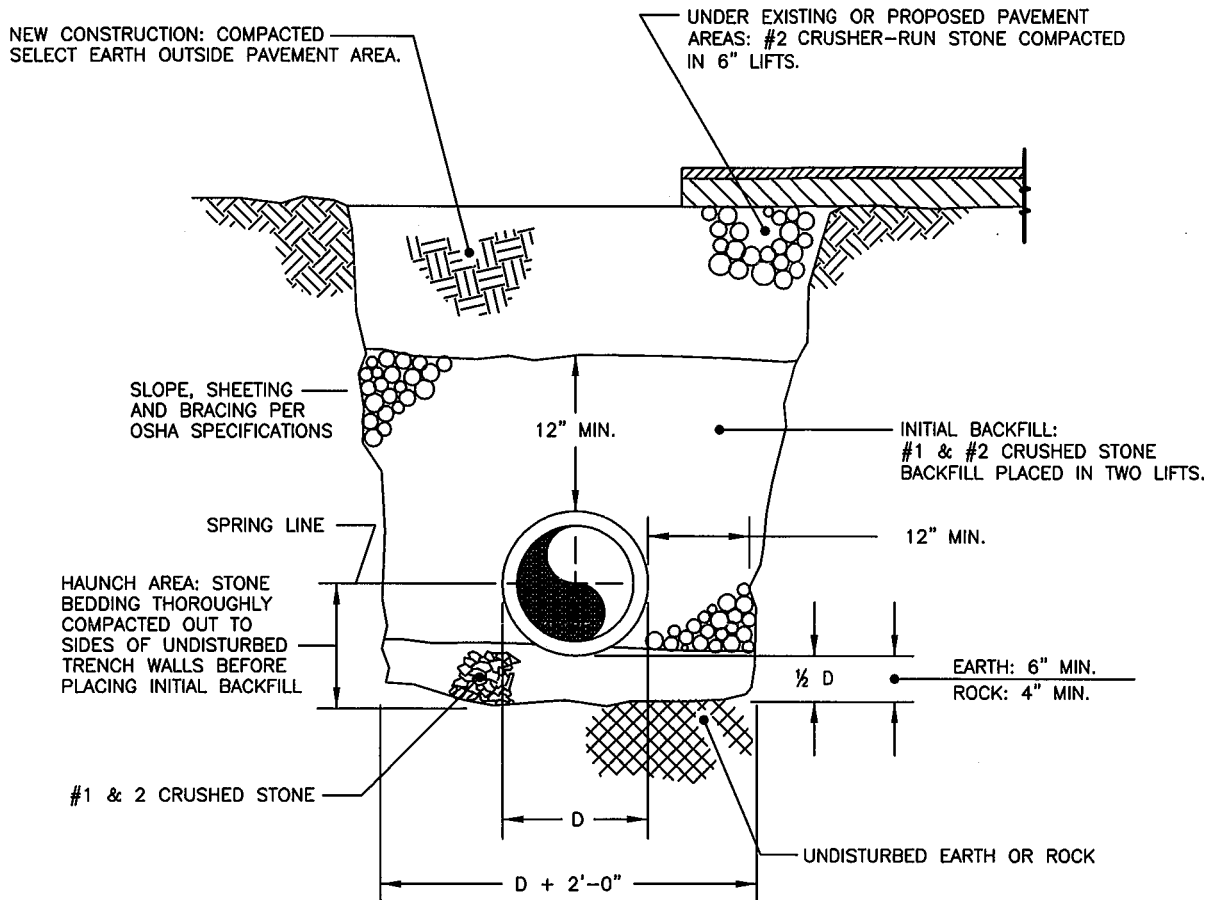

NOTES:

1. WHEN PIPE CROSSES UNDER PROPOSED NEW ROAD CONSTRUCTION WHERE UNSTABLE SOIL CONDITIONS EXIST, SELECT GRAVEL COMPACTED IN 12" LIFTS SHALL BE BACKFILLED FULL DEPTH OF TRENCH.
2. IN NEW CONSTRUCTION WHERE STORM AND SANITARY SEWERS CROSS EACH OTHER, THE TRENCH SHALL BE EXCAVATED DOWN TO THE PREVIOUSLY LAID SEWER AND BACKFILLED WITH COMPACTED #2 CRUSHER-RUN STONE TO INSURE ADEQUATE SUPPORT.
3. 8" MINIMUM PIPE DIAMETER IS REQUIRED FOR DEDICATION OF SANITARY MAINS.

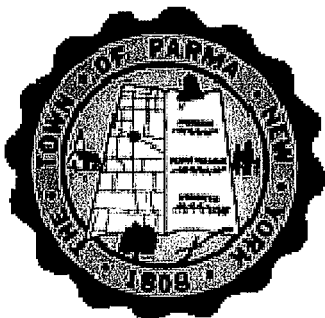

Standard Detail No. S-2
Typical Storm and Sanitary Sewer Trench
Scale: N.T.S.

Town of Parma
Development Regulations

October 2013

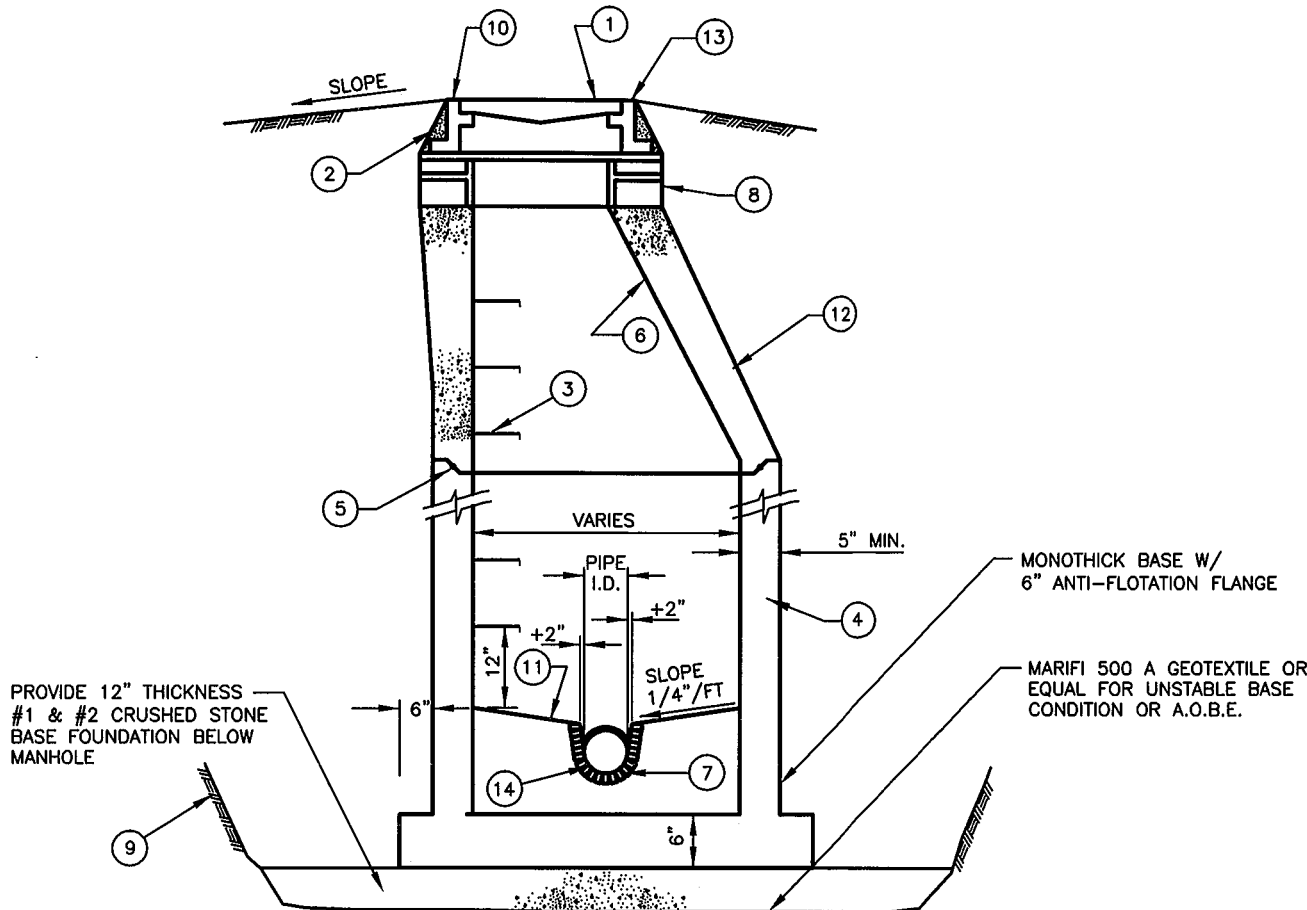

1. CAST IRON FRAME AND COVER, SEAL WITH ASPHALT BASE CEMENT
2. CONCRETE OR MORTAR OUTSIDE OF FRAME ALL THE WAY AROUND
3. MANHOLE STEPS SHALL BE CAST IN PLACE 12" O.C. POLYPROPYLENE PLASTIC COATED 1/2" GRADE 60 STEEL
4. STANDARD REINFORCED CONCRETE RISER SECTIONS CONFORMING ASTM C-78-64 T SPECIFICATION
5. TONGUE AND GROOVE JOINTS WITH "O" RING SEAL
6. PAINT INTERIOR WALLS WITH 2 COATS OF KOPPERS 300M BITUMASTIC COATING OR APPROVED EQUAL.
7. INVERT TO BE OF SEWER BRICK MEETING ASTM C-32 GRADE MA SPECIFICATION LAID IN CEMENT MORTAR. INVERT SHALL BE TRUE TO LINE & GRADE. HALF PIECE SECTIONS OF PIPE MAY BE USED FOR BOTTOM HALF OF INVERT IN STRAIGHT THROUGH MANHOLES (SANITARY ONLY).
8. PRECAST CONCRETE GRADE RINGS OR BRICK. MAXIMUM BUILD-UP 8". PLASTER ALL EXPOSED SURFACE WITH MORTAR INSIDE & OUTSIDE COAT INSIDE WITH 2 COATS OF KOPPERS 300M BITUMASTIC COATING OR APPROVED EQUAL.
9. ALL SLOPES ARE TO CONFORM TO OSHA STANDARDS.
10. FINISH GRADE (F.G.) FOR TOPS OF MANHOLE FRAMES & COVERS. PROVIDE POSITIVE SLOPE AWAY FROM MANHOLE COVER.
11. BENCH WORK AND TO TOP OF HIGHEST PIPE SHALL BE PROTECTED WITH 2 COATS OF SIKAGARD HI-BUILD 667 DURALKOTE OR APPROVED EQUAL. COATS SHALL BE DIFFERENT COLORS. SECOND COAT ON BENCH SURFACES TO CONTAIN ANTI-SLIP NODULES. 3000 PSI CONCRETE BENCH (SANITARY ONLY).
12. ECCENTRIC TAPER TOP FOR MANHOLE HEIGHT GREATER THAN 8 FEET. FLAT SLAB TOP FOR MANHOLE HEIGHT LESS THAN 8 FEET.
13. FINISH GRADE IS APPROXIMATE ONLY. CONTRATOR TO VERIFY IN THE FIELD PRIOR TO ORDERING MANHOLES.
14. PIPE TO MANHOLE CONNECTION SHALL BE WATER TIGHT, NEOPRENE RUBBER BOOT.

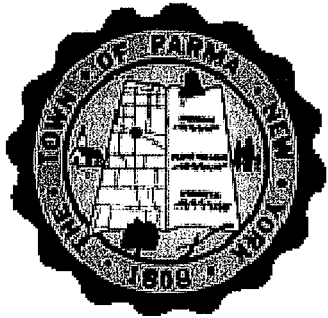

Standard Detail No. S-3
Sanitary and Storm Manhole Detail
Scale: N.T.S.

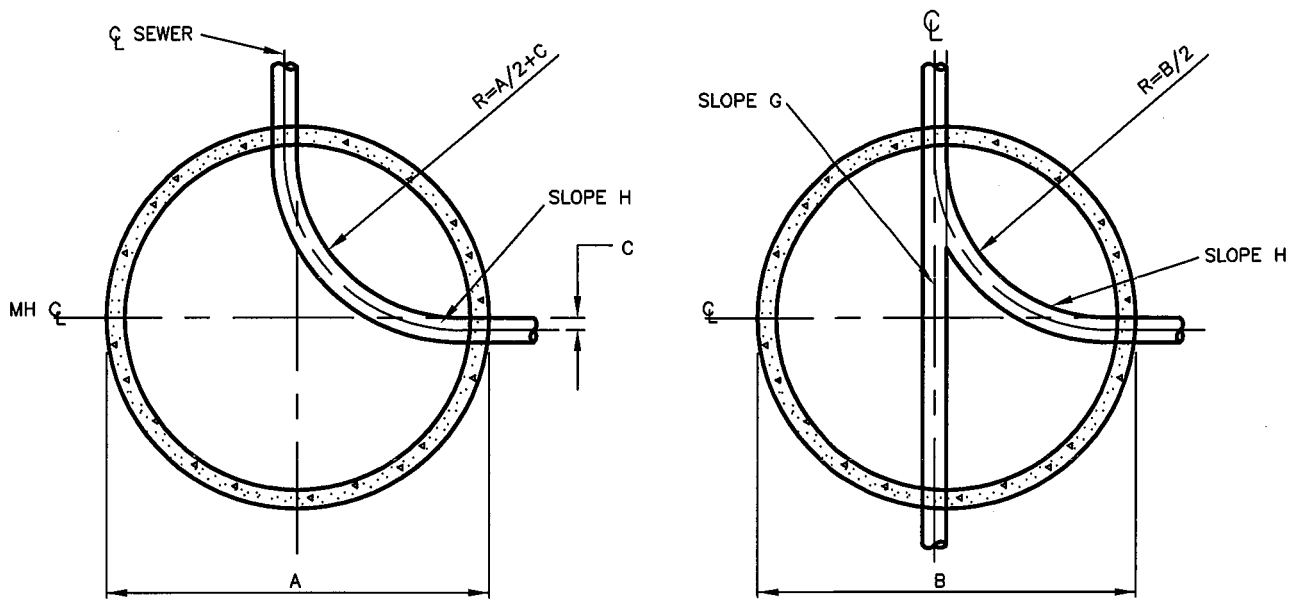

WHEN A SMALLER SEWER JOINS A LARGER ONE,
THE TOP OF PIPE SHALL BE MATCHED AT THE
SAME ELEVATION

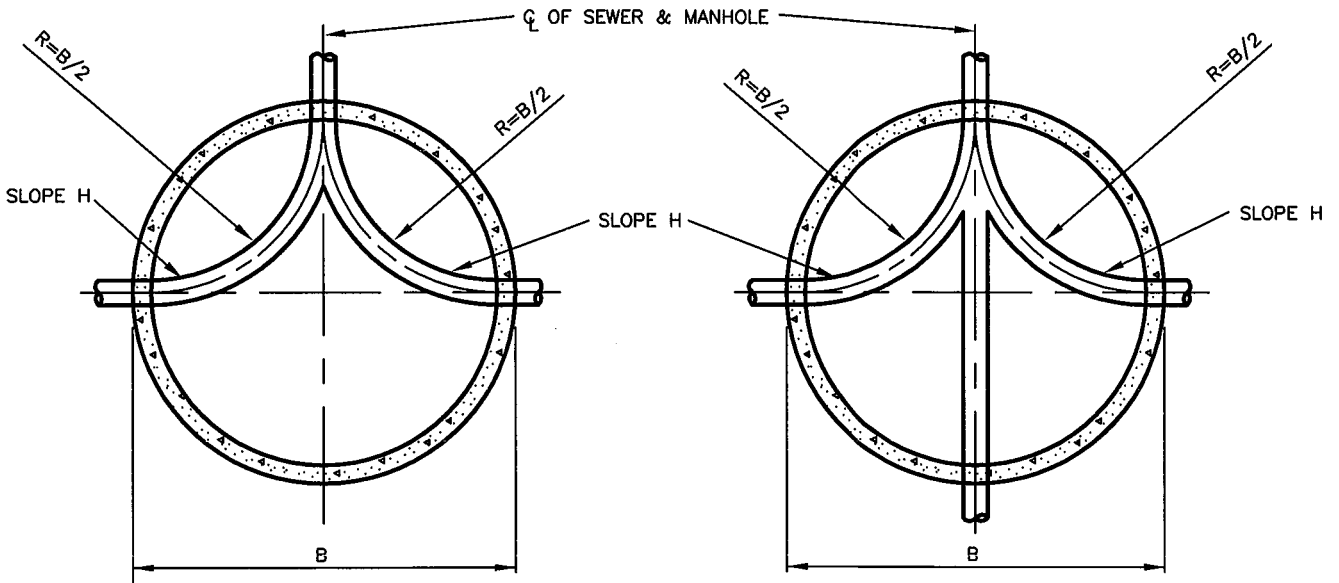

MAX. PIPE DIA.	8"	10"	12"	14"	16"	18"	20"	24"	27"	30"	36"
A	4'-0"	4'-0"	5'-0"	5'-0"	5'-0"	5'-0"	5'-0"	5'-0"	5'-0"	6'-0"	6'-0"
B	4'-0"	5'-0"	5'-0"	5'-0"	5'-0"	5'-0"	5'-0"	5'-0"	5'-0"	6'-0"	8'-0"
C	4"	5"	6"	7"	8"	9"	10"	12"	13.5"	15"	18"
G	0.05'	0.05'	0.05'	0.04'	0.02'	0.02'	0.02'	0.02'	0.02'	0.02'	0.02'
H	0.10'	0.10'	0.10'	0.07'	0.05'	0.05'	0.05'	0.05'	0.05'	0.05'	0.05'



Standard Detail No. S-4
Standard Manhole Dimensions
Scale: N.T.S.

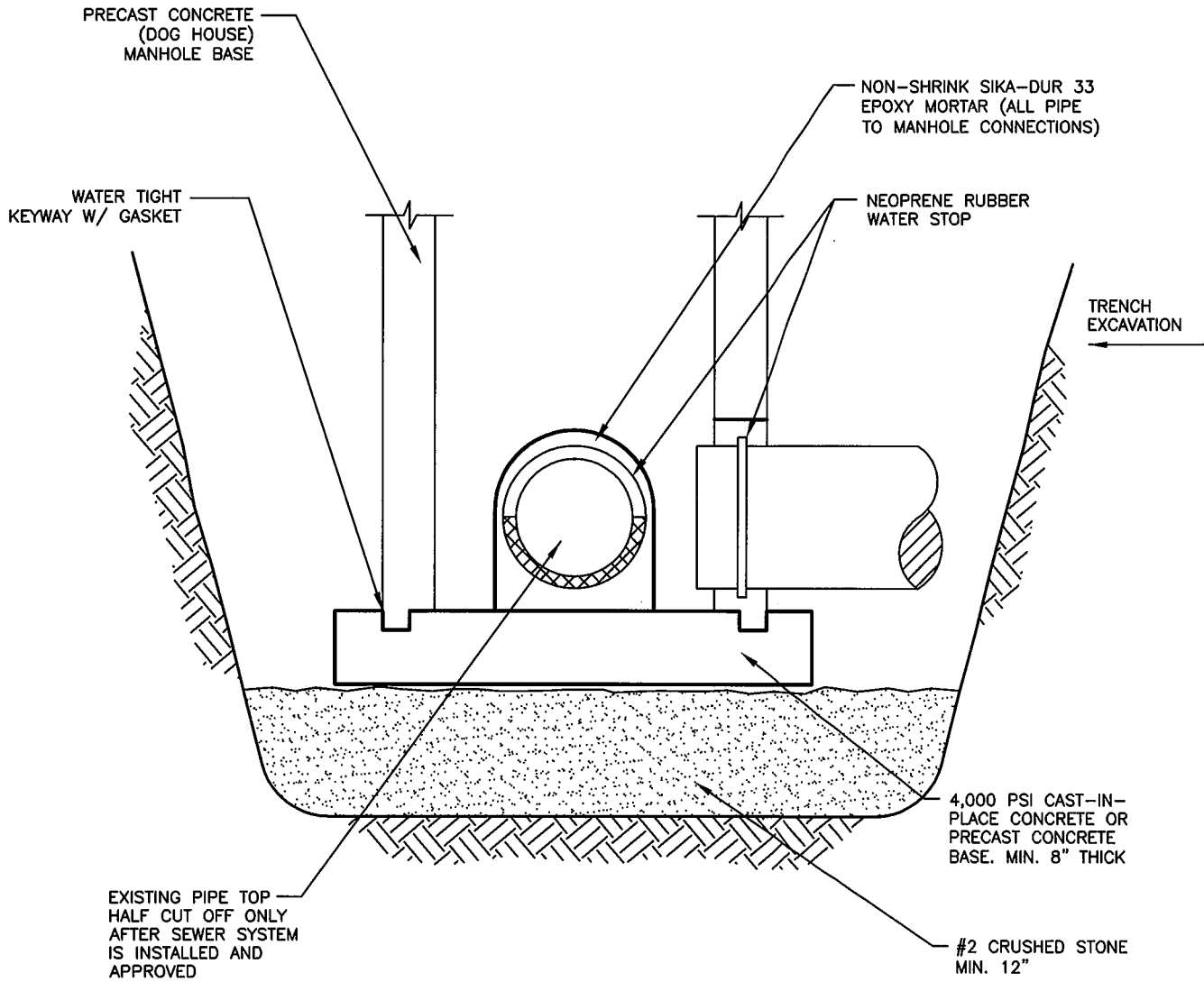

NOTES:

1. ALL OTHER ASPECTS OF THE MANHOLE CONSTRUCTION SHALL BE AS SHOWN ON SANITARY AND/OR STORM MANHOLE DETAIL, INCLUDING BENCH, INVERTS, STOPS, COATINGS, FRAMES, COVERS, AND STONE BASE.
2. DOGHOUSE MANHOLES MAY BE USED ONLY WHERE TIE-IN TO AN EXISTING PIPE IS REQUIRED AND WHERE FLOWS IN EXISTING PIPE CANNOT BE READILY BYPASSED, AS DETERMINED BY THE TOWN ENGINEER.

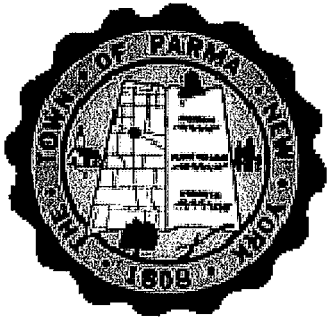

Standard Detail No. S-5
 Dog-House Manhole Detail
 Scale: N.T.S.

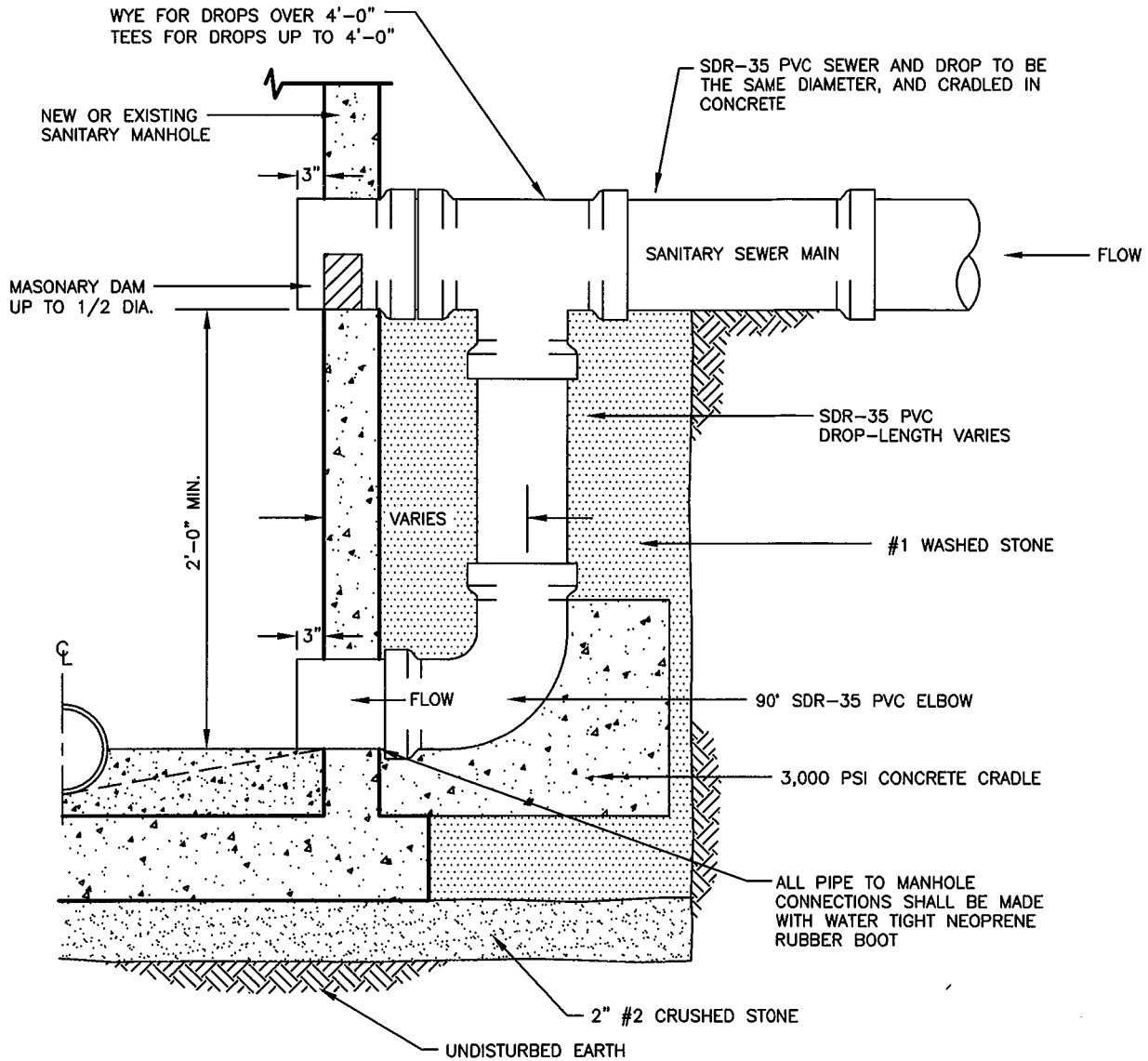

NOTES:

1. SEE SANITARY MANHOLE DETAIL FOR ALL OTHER CONSTRUCTION FEATURES NOT SHOWN HERE.
2. CONCRETE CASING SURROUNDING ELBOW SHALL BE A MINIMUM 6" THICKNESS ON ALL SIDES OF THE PIPE WALL.
3. SEWER PIPES SHALL NOT ENTER MANHOLE AT JOINTS BETWEEN SECTIONS OF MANHOLE BARREL.
4. PROVIDE BENCH FOR DROP AS SHOWN ON SANITARY MANHOLE DETAIL.
5. CONSTRUCT A MASONRY DAM FROM INVERT TO CENTERLINE OF PIPE AT CLEANOUT.
6. PIPE OPENINGS SHALL BE CORED & FILLED WITH EPOXY MORTAR SIKADUR 33 OR EQUAL; TO MAKE WATER TIGHT CONNECTION. PRECAST OPENINGS ARE ALLOWABLE.

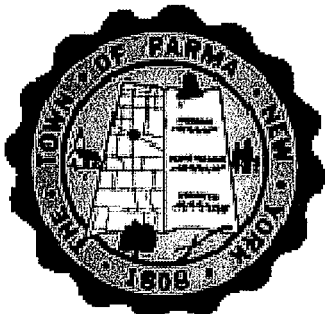

Standard Detail No. S-6
Outside Drop Connection
Scale: N.T.S.

Town of Parma
Development Regulations

October 2013

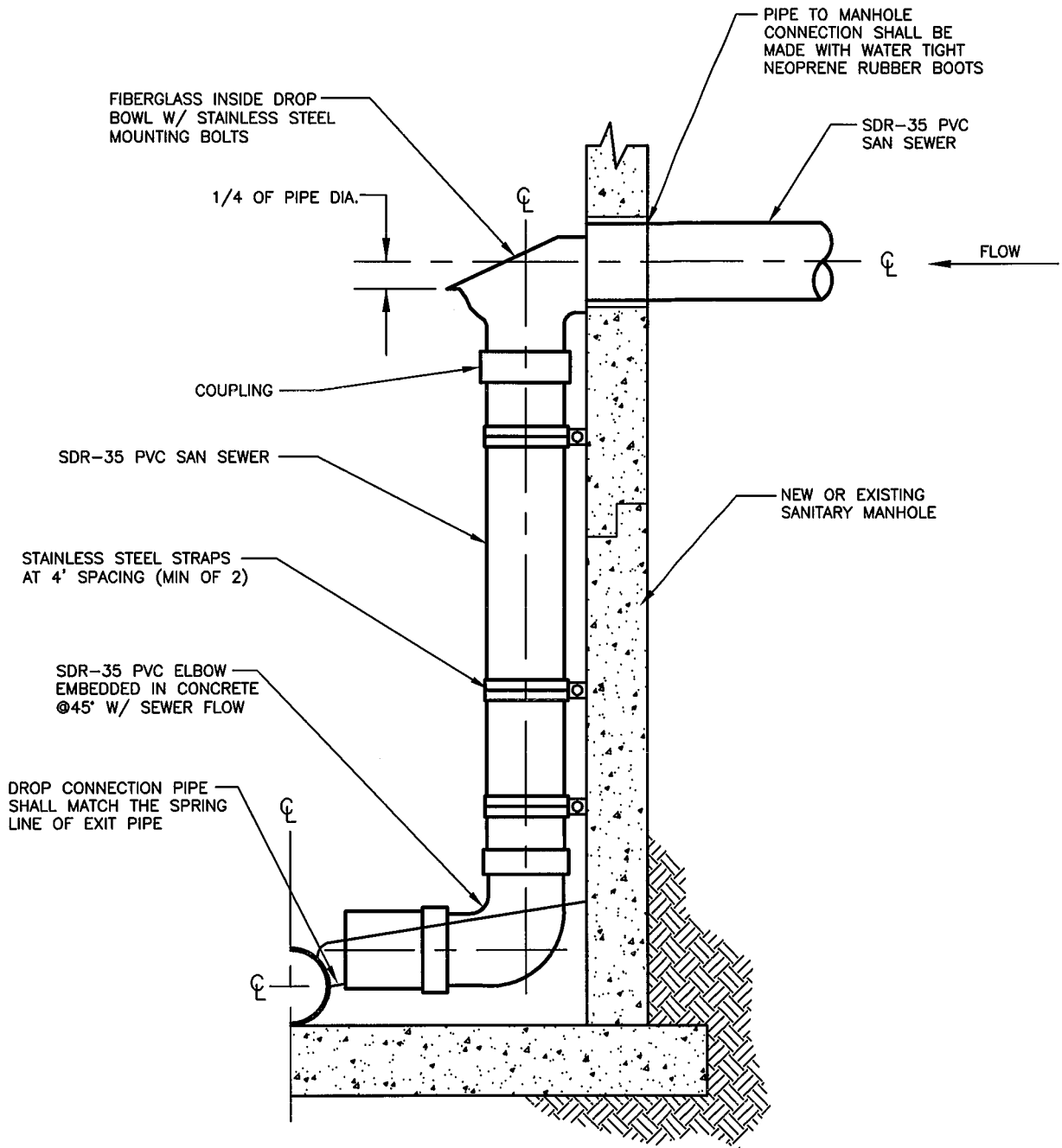

INSIDE DROP NOTES:

1. ALL FITTINGS TO BE CONSTRUCTED OF SDR-35 PIPE.
2. MINIMUM 5' DIAMETER MANHOLE REQUIRED FOR INSIDE DROP CONNECTORS. MINIMUM OF 4' OF CLEARANCE IS REQUIRED FOR INSIDE DROP MANHOLES.
3. SEE SANITARY MANHOLE DETAIL FOR ALL OTHER CONNECTION FEATURES NOT SHOWN HERE.

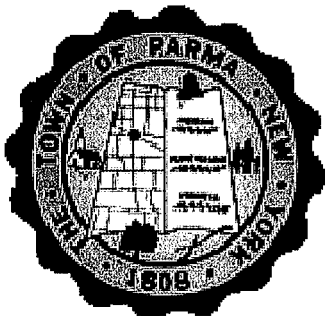

Standard Detail No. S-7
 Inside Drop Connection
 Scale: N.T.S.

WATER MAIN/SEWER CROSSING DETAIL

CONDITION	SCHEMATIC	REQUIREMENTS
<p>I</p> <p>WATER LINE ABOVE SEWER LINE</p>		<p>A) WATER LINE AND SEWER LINE PIPE LENGTHS TO BE CENTERED AT CROSSING. EACH LENGTH OF PIPE TO BE 10 FT. MINIMUM.</p>
<p>II</p> <p>SEWER LINE ABOVE WATER LINE</p>		<p>A) WATER LINE AND SEWER LINE PIPE LENGTHS TO BE CENTERED AT CROSSING. EACH LENGTH OF PIPE TO BE 10 FT. MINIMUM.</p> <p>B) SLEEVE SEWER LINE WITH "STEEL CASING FOR 10 FT." EACH SIDE OF CROSSING.</p> <p>C) PROVIDE CRADLE OF CONCRETE OR CRUSHER RUN STONE (SEE TRENCH SECTION DETAIL BELOW) FOR WATER LINE AND SEWER LINE FOR 10 FT. EACH SIDE OF CROSSING.</p>
<p><u>NOTES</u></p> <p>WL (WATER LINE)</p> <p>SL (SEWER LINE, SANITARY OR STORM)</p> <p>D (OUTSIDE DIAMETER OF PIPE)</p> <p>IN NO CASE SHALL PIPES BE CLOSER THAN 18 INCHES APART. DISTANCES ARE MEASURED BETWEEN OUTSIDES OF PIPE.</p>		



Standard Detail No. S-9
 Water Main/Sewer Crossing Detail
 Scale: N.T.S.

Town of Parma
 Development Regulations

October 2013

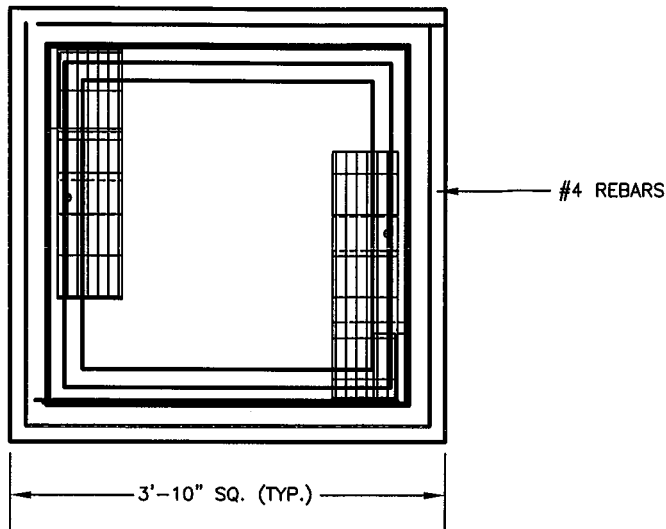

PLAN VIEW

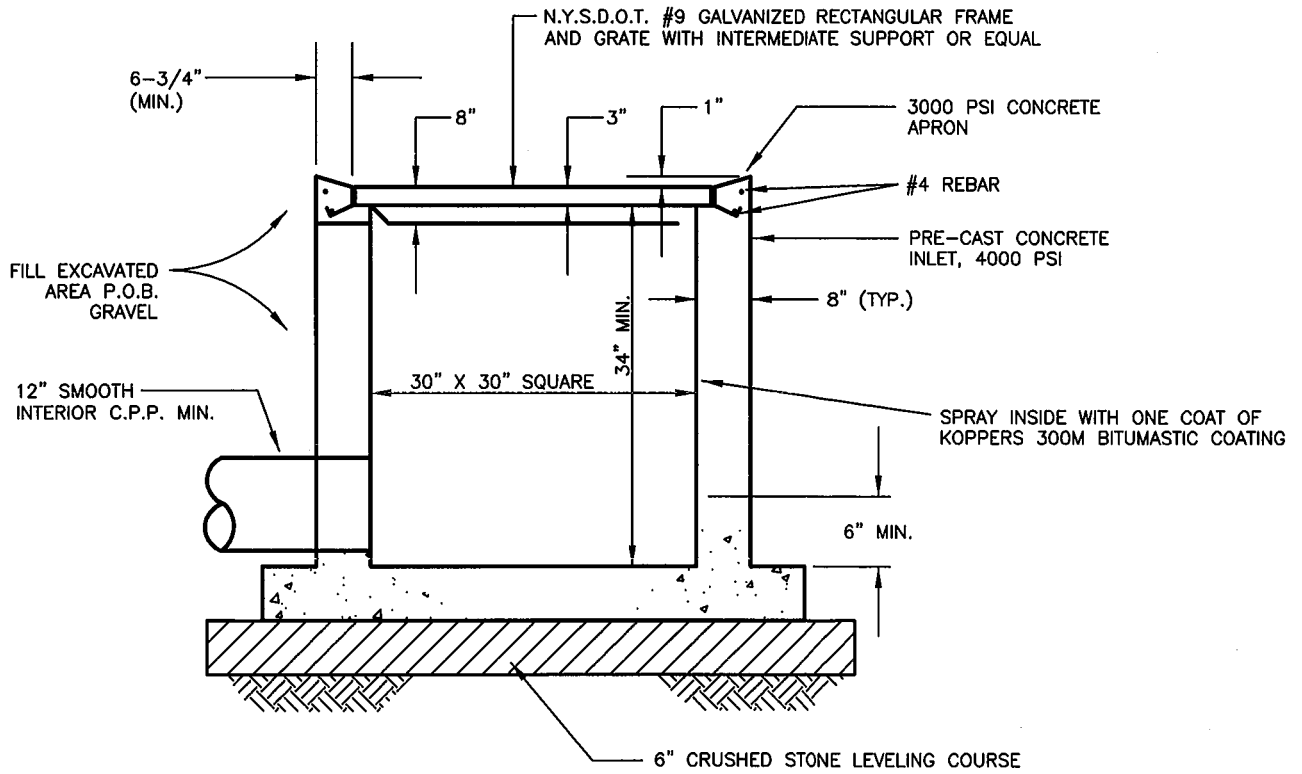

SECTION VIEW

Standard Detail No. S-10
 Typical Field Inlet
 Scale: N.T.S.

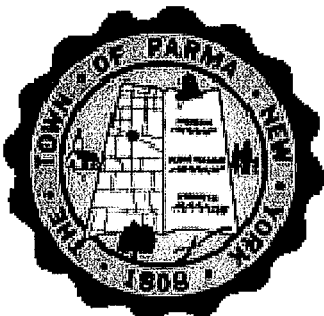

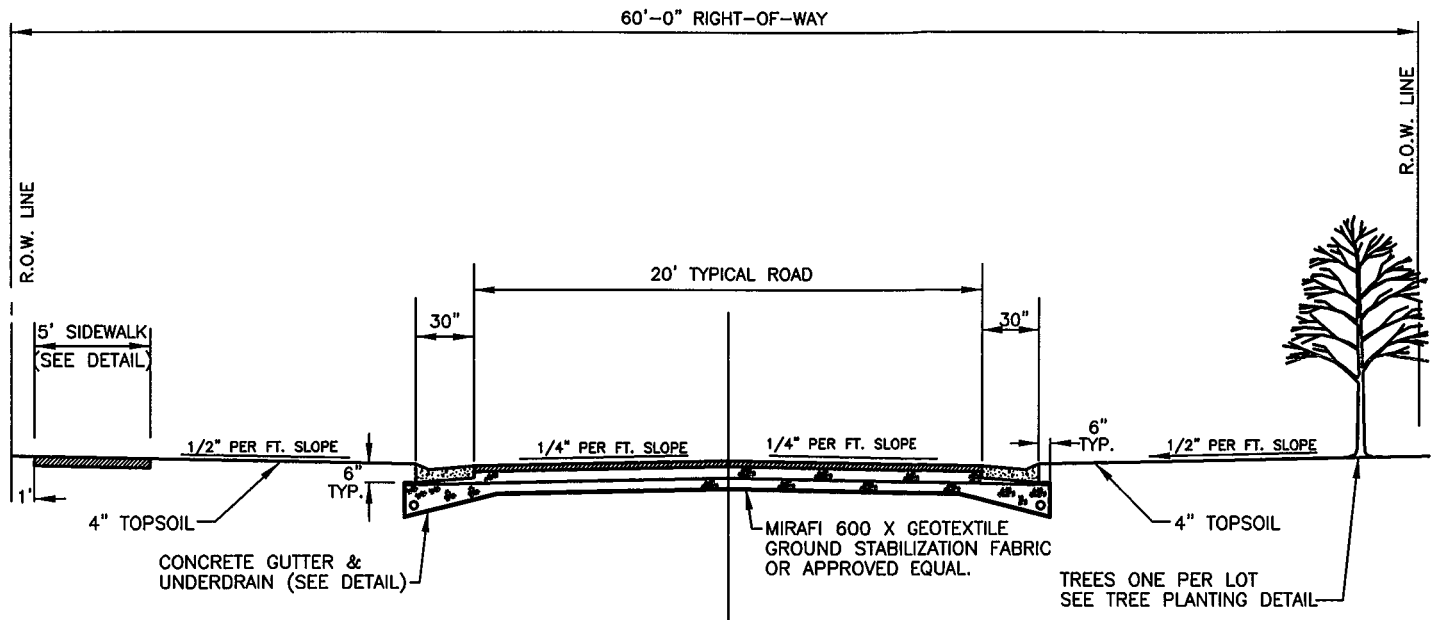

NOTES:

1. PAVEMENT SECTION

- 1" COMPACTED THICKNESS OF NYSDOT TYPE 7F TOP COURSE
- 3" COMPACTED THICKNESS OF NYSDOT TYPE 3 BINDER COURSE
- TYPICAL BASE: 2-6" COMPACTED THICKNESS LAYERS OF NYSDOT ITEM 304.2 (NO. 2 LIMESTONE CRUSHER RUN)
- ALTERNATE BASE: WHERE DIRECTED BY HIGHWAY SUPT.
- 2-4-1/2" COMPACTED THICKNESS LAYERS OF NYSDOT ITEM 304.2 (NO. 2 LIMESTONE CRUSHER RUN)
- 3" NO. 3 CRUSHED STONE NYSDOT 703-020

- 2. MATERIALS, EQUIPMENT AND WORK SHALL BE DONE IN ACCORDANCE WITH NYS DOT REQUIREMENTS, INCLUDING TEMPERATURES, COMPACTION EQUIPMENT, ETC.
- 3. ALL FILL UNDER ROAD SECTIONS SHALL BE COMPACTED TO A MINIMUM OF 90% MODIFIED A.A.S.H.T.O. DENSITY.
- 4. ALL TOP SOIL, STUMPS, ROOTS OR OTHER ORGANIC MATERIAL TO BE REMOVED PRIOR TO PLACING FILL OR SHAPING OF ROAD BOX.
- 5. SIDEWALK SHALL BE ON ONE SIDE OF THE STREET (UNLESS REQUIRED BOTH SIDES BY THE PLANNING BOARD).
- 6. MINIMUM DISTANCE OF 10' TO R.O.W. OR A PERMANENT UTILITY EASEMENT IS TO BE PROVIDED.
- 7. PERFORATED UNDERDRAINS TO BE INSTALLED BOTH SIDES OF PAVEMENT, FULL LENGTH OF ROAD AND CONNECTED TO EACH CATCH BASIN.
- 8. FOR PAVING MINIMUM SURFACE TEMPERATURE SHALL BE 45°F.
- 9. BITUMINOUS TACK COAT SHALL BE APPLIED TO CONCRETE SURFACES PRIOR TO PAVING.
- 10. BITUMINOUS TACK COAT SHALL BE APPLIED TO BINDER SURFACE PRIOR TO INSTALLATION OF ASPHALT TOP. BINDER SHALL GO THROUGH AT LEAST ONE WINTER SEASON PRIOR TO THE INSTALLATION OF THE ASPHALT TOP.
- 11. ALL UNPAVED AREAS WITHIN R.O.W. ARE TO BE GRADED WITH 4" TOPSOIL, FERTILIZED AND SEED.



Standard Detail No. H-1
 Typical Town Road Section
 Scale: N.T.S.

Town of Parma
 Development Regulations

October 2013

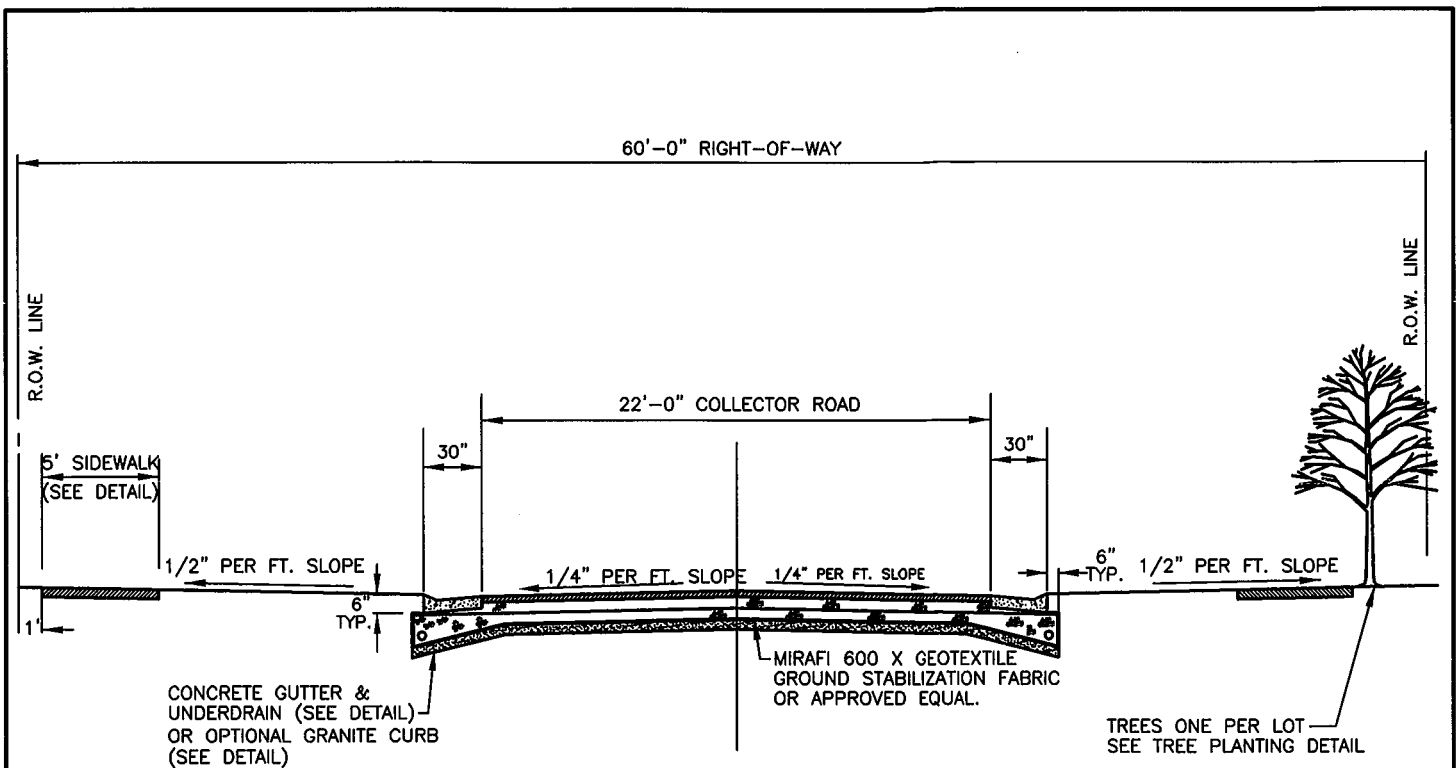

NOTES:

1. PAVEMENT SECTION

- 1" COMPACTED THICKNESS OF NYSDOT TYPE 7F TOP COURSE
- 3" COMPACTED THICKNESS OF NYSDOT TYPE 3 BINDER COURSE
- 2-2 1/2" COMPACTED THICKNESS LAYERS OF NYSDOT TYPE 1 ASPHALT
- TYPICAL BASE: 2-6" COMPACTED THICKNESS LAYERS OF NYSDOT ITEM 304.2 (NO. 2 LIMESTONE CRUSHER RUN)
- ALTERNATE BASE: AS DIRECTED BY HIGHWAY SUPT.
- 2-4-1/2" COMPACTED THICKNESS LAYERS OF NYSDOT ITEM 304.2 (NO. 2 LIMESTONE CRUSHER RUN)
- 3" NO. 3 CRUSHED STONE NYSDOT 703-0201

- 2. MATERIALS, EQUIPMENT AND WORK SHALL BE DONE IN ACCORDANCE WITH NYS DOT REQUIREMENTS, INCLUDING TEMPERATURES, COMPACTION EQUIPMENT, ETC.
- 3. ALL FILL UNDER ROAD SECTIONS SHALL BE COMPACTED TO A MINIMUM OF 90% MODIFIED A.A.S.H.T.O. DENSITY.
- 4. ALL TOP SOIL, STUMPS, ROOTS OR OTHER ORGANIC MATERIAL TO BE REMOVED PRIOR TO PLACING FILL OR SHAPING OF ROAD BOX.
- 5. SIDEWALK SHALL BE ON ONE SIDE OF THE STREET (UNLESS REQUIRED BOTH SIDES BY THE PLANNING BOARD).
- 6. MINIMUM DISTANCE OF 10' TO R.O.W. OR A PERMANENT UTILITY EASEMENT IS TO BE PROVIDED.
- 7. PERFORATED UNDERDRAINS TO BE INSTALLED BOTH SIDES OF PAVEMENT, FULL LENGTH OF ROAD AND CONNECTED TO EACH CATCH BASIN.
- 8. FOR PAVING MINIMUM SURFACE TEMPERATURE SHALL BE 45°F.
- 9. BITUMINOUS TACK COAT SHALL BE APPLIED TO CONCRETE SURFACES PRIOR TO PAVING.
- 10. BITUMINOUS TACK COAT SHALL BE APPLIED TO BINDER SURFACE PRIOR TO INSTALLATION OF ASPHALT TOP. BINDER SHALL GO THROUGH AT LEAST ONE WINTER SEASON PRIOR TO THE INSTALLATION OF THE ASPHALT TOP.
- 11. ALL UNPAVED AREAS WITHIN R.O.W. ARE TO BE GRADED WITH 4" TOPSOIL, FERTILIZED AND SEEDED.
- 12. COLLECTOR ROAD SHALL BE REQUIRED WHEN SERVING 150 DWELLING UNITS OR MORE OR WHERE REQUIRED BY THE PLANNING BOARD DUE TO HEAVY TRAFFIC.

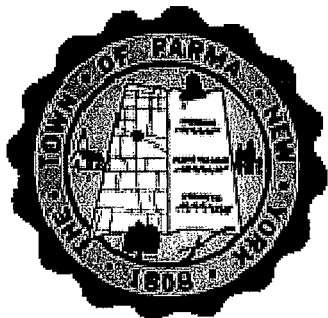

**Standard Detail No. H-2
Typical Collector Road Section
Scale: N.T.S.**

**Town of Parma
Development Regulations**

October 2013

NOTE: ALL UTILITIES TO BE UNDERGROUND

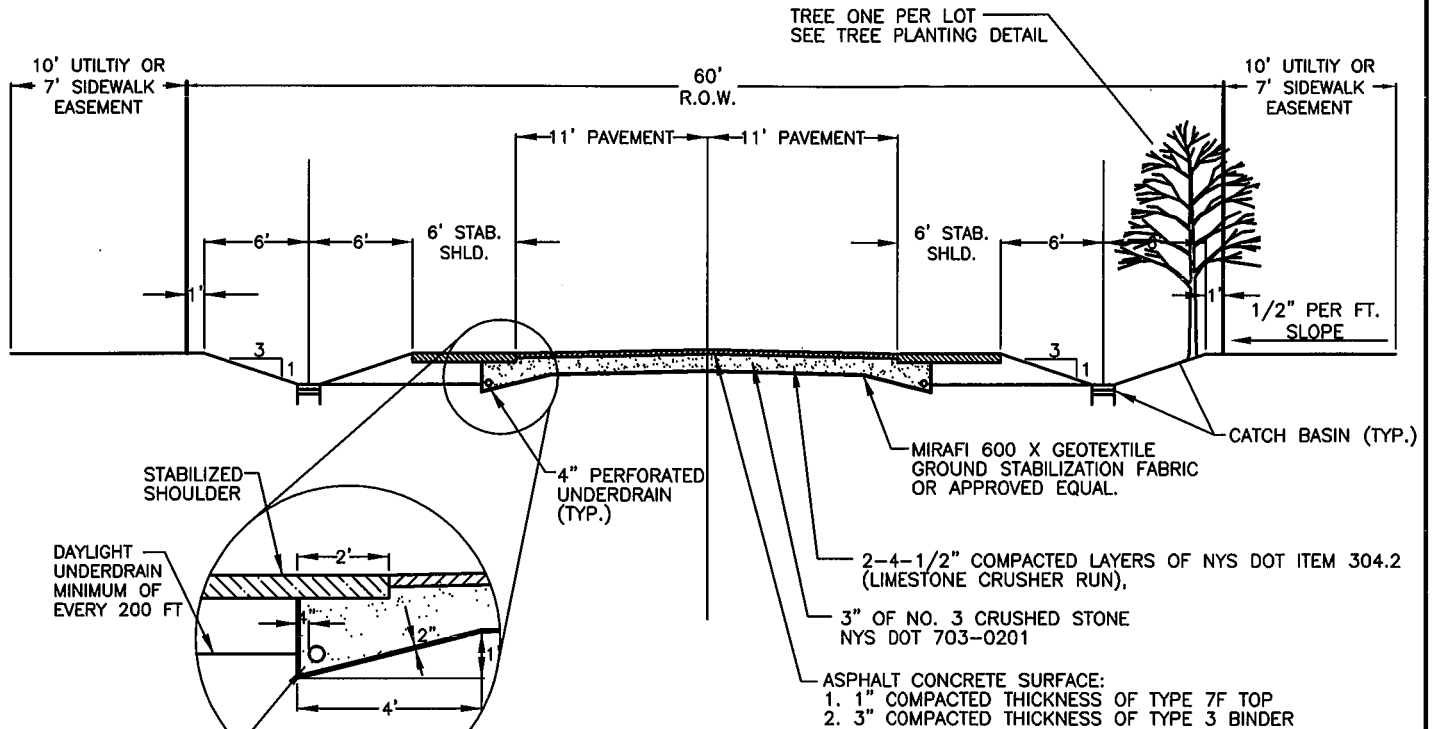

NOTES:

1. ROAD WITH STABILIZED SHOULDER MAY BE ALLOWED ONLY IN THE RURAL RESIDENTIAL AND AC ZONING DISTRICT WHERE SANITARY SEWER IS NOT AVAILABLE; AND WHERE SERVING 12 UNITS OR LESS
2. BASE SHALL BE ROLLED AND COMPACTED WITH A VIBRATORY ROLLER CAPABLE OF PRODUCING A MINIMUM DYNAMIC VIBRATION FORCE OF 27,000 LBS.
3. ALL TOP SOIL, STUMPS, ROOTS OR OTHER ORGANIC MATERIAL TO BE REMOVED PRIOR TO PLACING FILL OR SHAPING OF ROAD BOX.
4. CONSTRUCTION SEASON FOR ROAD CONSTRUCTION SHALL BE FROM MAY 15 TO OCTOBER 15 UNLESS OTHERWISE APPROVED BY THE TOWN HIGHWAY SUPERINTENDENT.
5. STABILIZED SHOULDER SHALL CONSIST OF MIN. 6 INCHES OF CRUSHED STONE AND BITUMINOUS MATERIAL MEETING NYSDOT 410.05 BITUMINOUS SURFACE TREATMENT
6. CONSTRUCTION SHALL BE IN ACCORDANCE WITH N.Y.S.D.O.T. GENERAL SPECIFICATIONS FOR BITUMINOUS CONCRETE, EXCEPT THAT TOPPING SHALL BE LAID IN THE YEAR FOLLOWING THE INSTALLATION OF THE BINDER SURFACING. MINIMUM LAYING TEMPERATURE 250°F. MINIMUM SURFACE TEMPERATURE SHALL BE 45°F.
7. UTILITIES SUCH AS GAS, WATERMAIN, TELEPHONE, SHALL BE SHOWN ON THE TYPICAL UTILITY LAYOUT SECTION.
8. UNDERDRAIN SHALL DAYLIGHT TO ROADSIDE SWALE AT MAX. 200' SPACING
9. ALL UNPAVED AREAS WITHIN R.O.W. ARE TO BE GRADED WITH 4" TOPSOIL, FERTILIZED AND SEEDDED.
10. CONCRETE PAVED INVERT OR STORM DRAINAGE PIPING SHALL BE PROVIDED WHEN SWALE SLOPE EXCEEDS 3.5%.



**Standard Detail No. H-3
Typical Parkway Road
Scale: N.T.S.**

**Town of Parma
Development Regulations**

October 2013

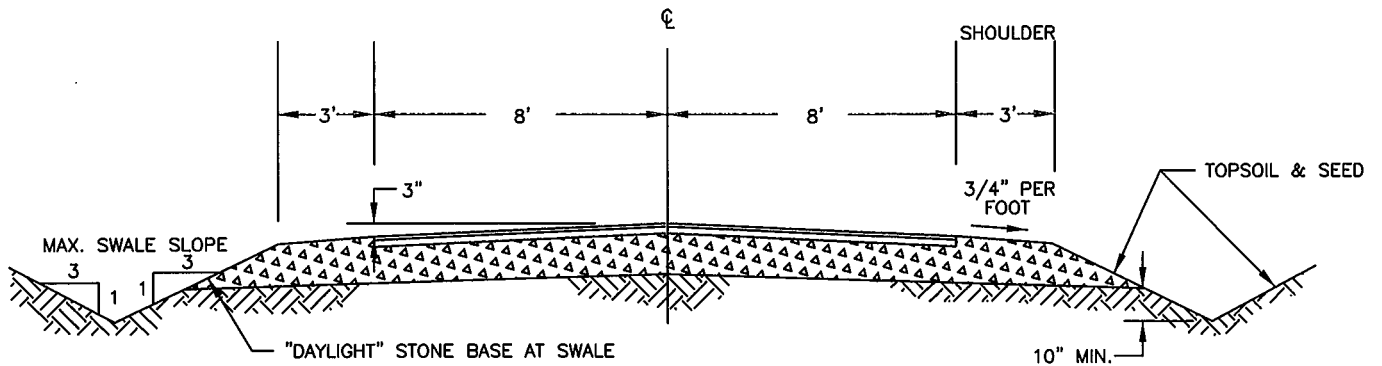

NOTES:

1. 9" CRUSHED STONE PAVEMENT BASE SHALL CONSIST OF 5" NO. 2 CRUSHER RUN ROLLED AND COMPACTED FOLLOWED BY 4" OF NO. 2 CRUSHER RUN COMPACTED. STONE SHALL BE CRUSHED LIMESTONE MEETING N.Y.S.D.O.T. SECTION 304.
2. BITUMINOUS SURFACE TREATMENT SHALL CONFORM TO N.Y.S.D.O.T. SPECIFICATIONS ITEM 410.04
3. ALL TOPSOIL, STUMPS, ROOTS, OR OTHER ORGANIC MATERIAL TO BE REMOVED PRIOR TO PLACING FILL OR SHAPING ROAD BOX.
4. INSPECTION OF ROAD CONSTRUCTION BY TOWN ENGINEER ARE REQUIRED FOR: ROAD SUB-BASE, STONE BASE, & SURFACE TREATMENT.
5. PROPERTY OWNERS SHALL MAINTAIN ROAD FOR CONTINUOUS ACCES FOR EMERGENCY VEHICLES.
6. PRIVATE ROADS MAY SERVE A MAXIMUM OF 3 UNITS.

(TO SERVE UP TO 3 RESIDENTIAL UNITS)

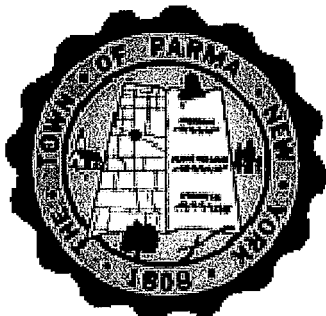

Standard Detail No. H-4
 Typical Private Road Section
 Scale: N.T.S.

Town of Parma
 Development Regulations

October 2013

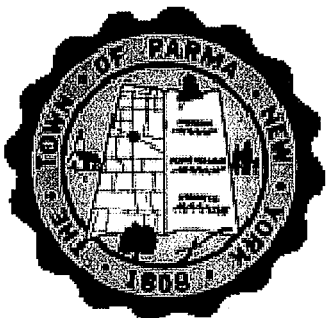
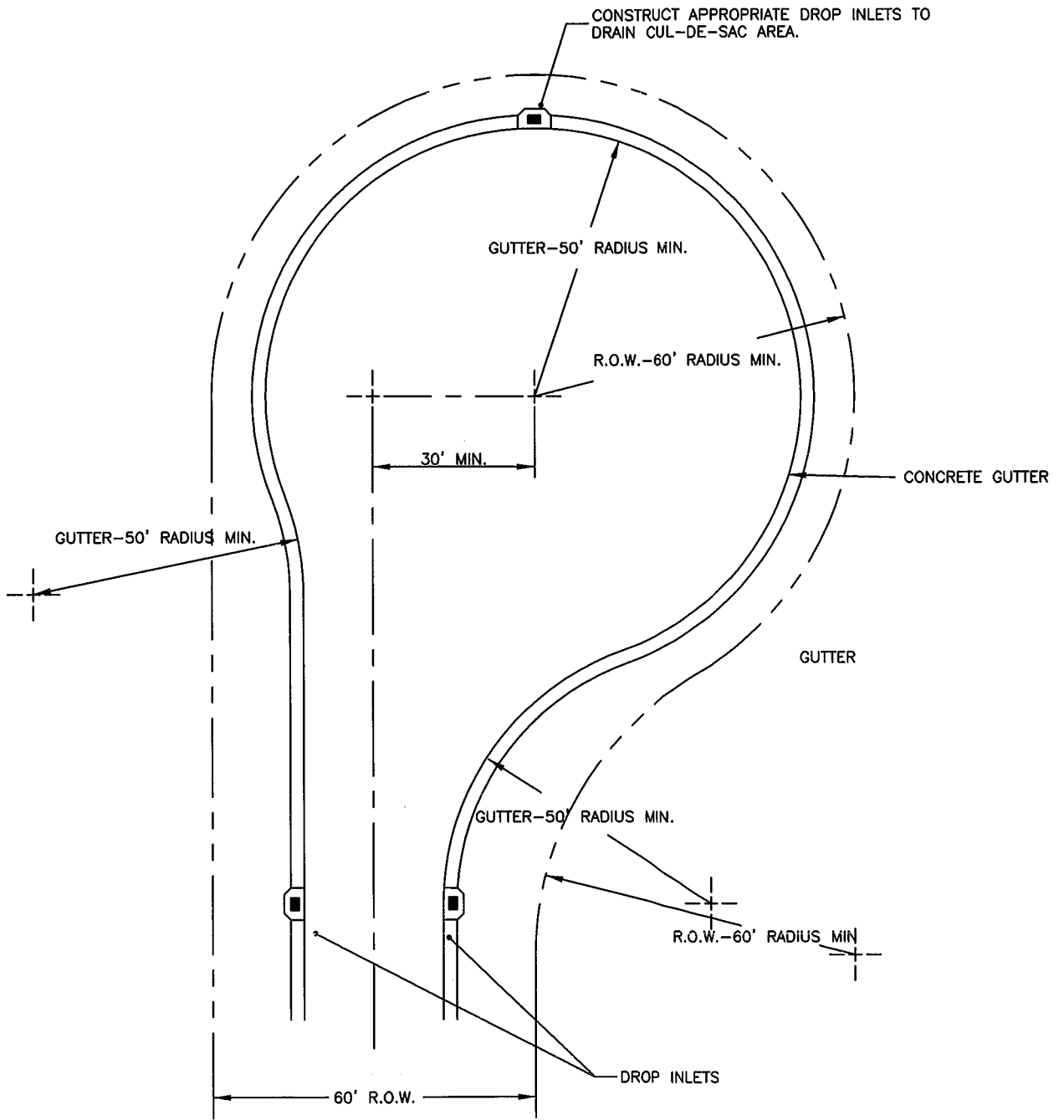

Standard Detail No. H-5
 Typical Cul-de-sac Detail
 Scale: N.T.S.

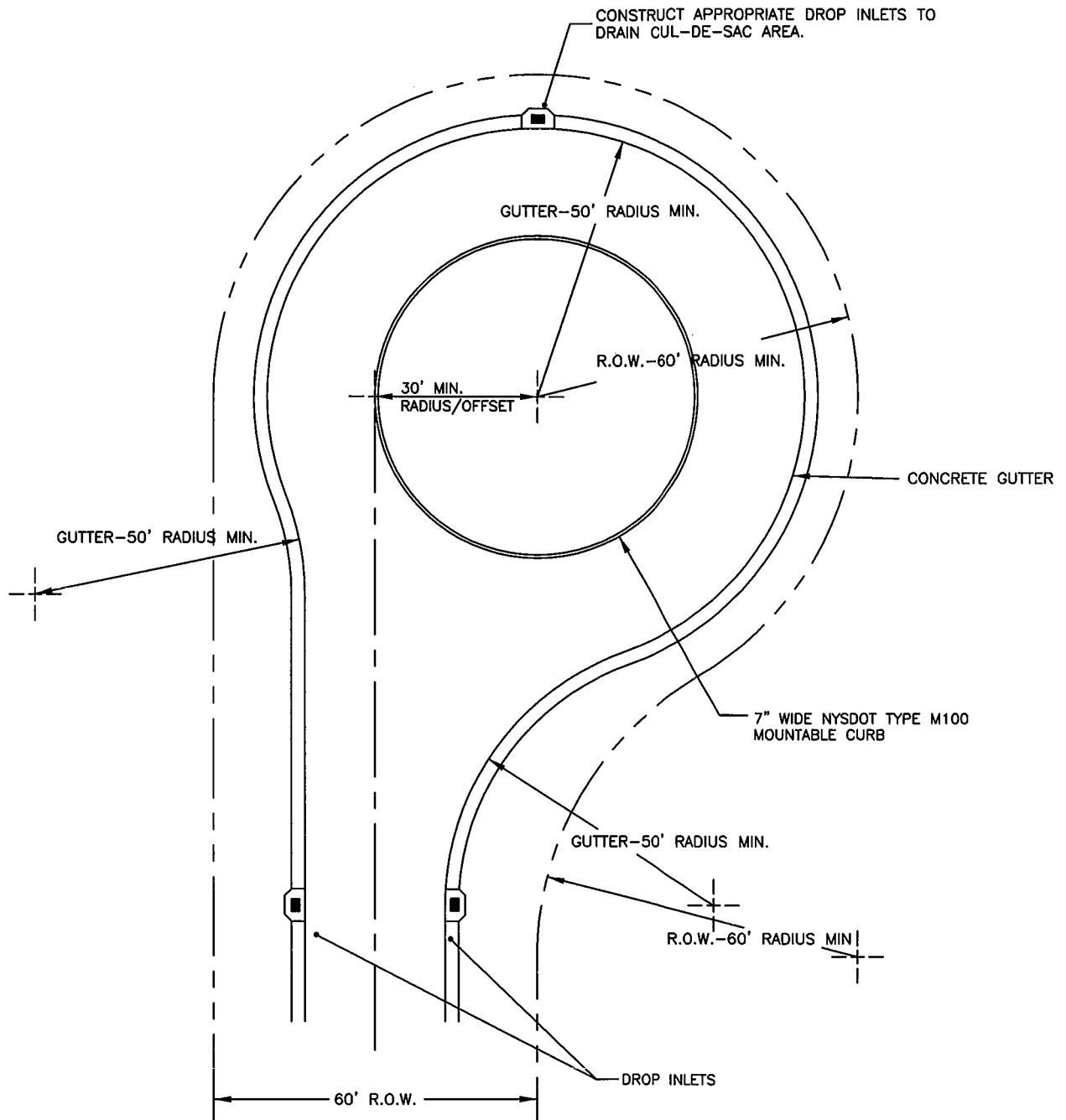

NOTES:

1. LANDSCAPED ISLAND MAY BE RAISED TO PROMOTE DRAINAGE TO GUTTER SYSTEM OR DEPRESSED TO SERVE AS A RAIN GARDEN. SLOPE CURB BASED ON DESIGN.
2. LANDSCAPE SHALL BE DESIGNED BY A NYS LICENSED LANDSCAPE ARCHITECT OR CERTIFIED NURSERY AND LANDSCAPE PROFESSIONAL. ALL PLANTS SHALL BE LOW MAINTENANCE AND SUBJECT TO THE APPROVAL BY THE PLANNING BOARD AND HIGHWAY SUPERINTENDENT.

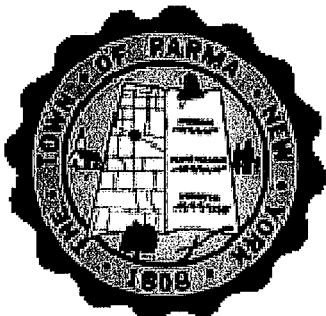

Standard Detail No. H-6
Typical Cul-de-sac with Landscaped Island Detail
Scale: N.T.S.

Town of Parma
 Development Regulations

October 2013

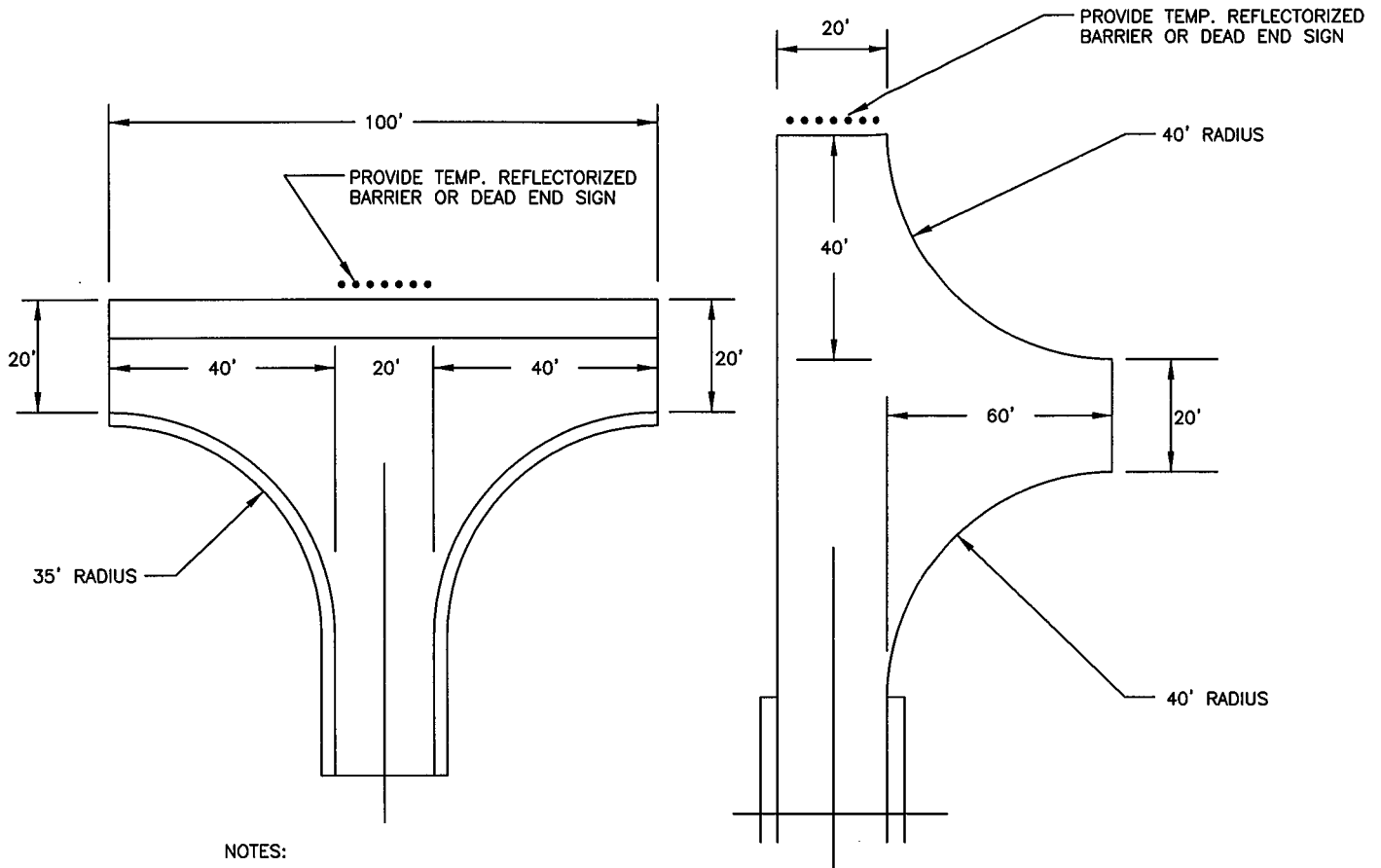

NOTES:

1. PROVIDE PERMANENT EASEMENT FOR FUTURE CUL-DE-SAC, IF APPLICABLE.
2. PRIVATE DRIVEWAYS SHALL NOT EXIT INTO OR WITHIN 20' OF TEMPORARY TURN-AROUND.
3. THE LETTER OF CREDIT SHALL INCLUDE AN ITEM FOR A PERMANENT CUL-DE-SAC OR TURN AROUND. THIS ITEM SHALL BE HELD BY THE TOWN UNTIL DEVELOPMENT OF FUTURE SECTIONS.
4. TEMPORARY TURN-AROUND SHALL BE CONSTRUCTED OF 9" CRUSHER RUN COMPACTED THICKNESS AND PAVED WITH 3" TYPE 3 BINDER IF IN USE MORE THAN ONE (1) YEAR.
5. TURN-AROUND SHALL HAVE R.O.W. WIDTH EQUAL TO THE ENTERING STREET OR MINIMUM OF 60 FEET, WHICHEVER IS GREATER.
5. R.O.W. TO EXTEND MINIMUM 10' BEYOND PAVEMENT.

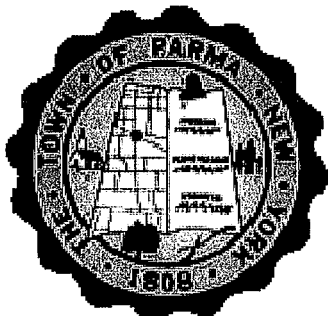

Standard Detail No. H-8
 Typical Temporary Turn-Around Detail
 Scale: N.T.S.

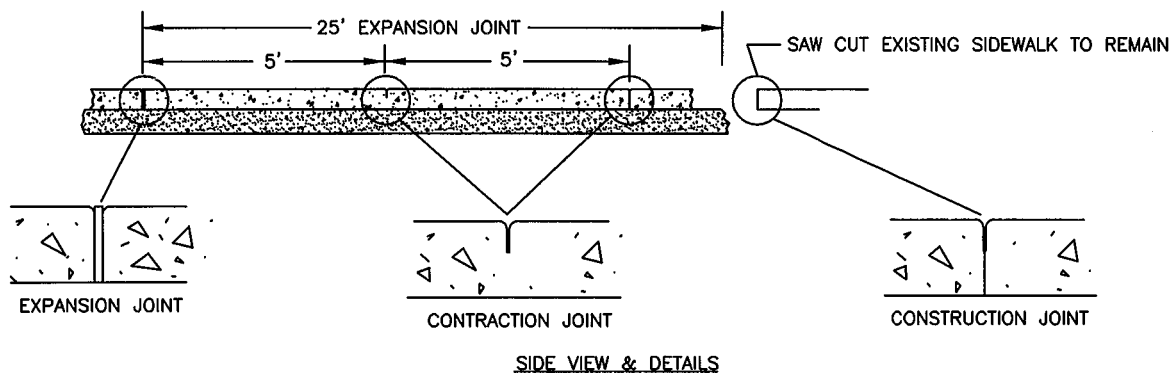
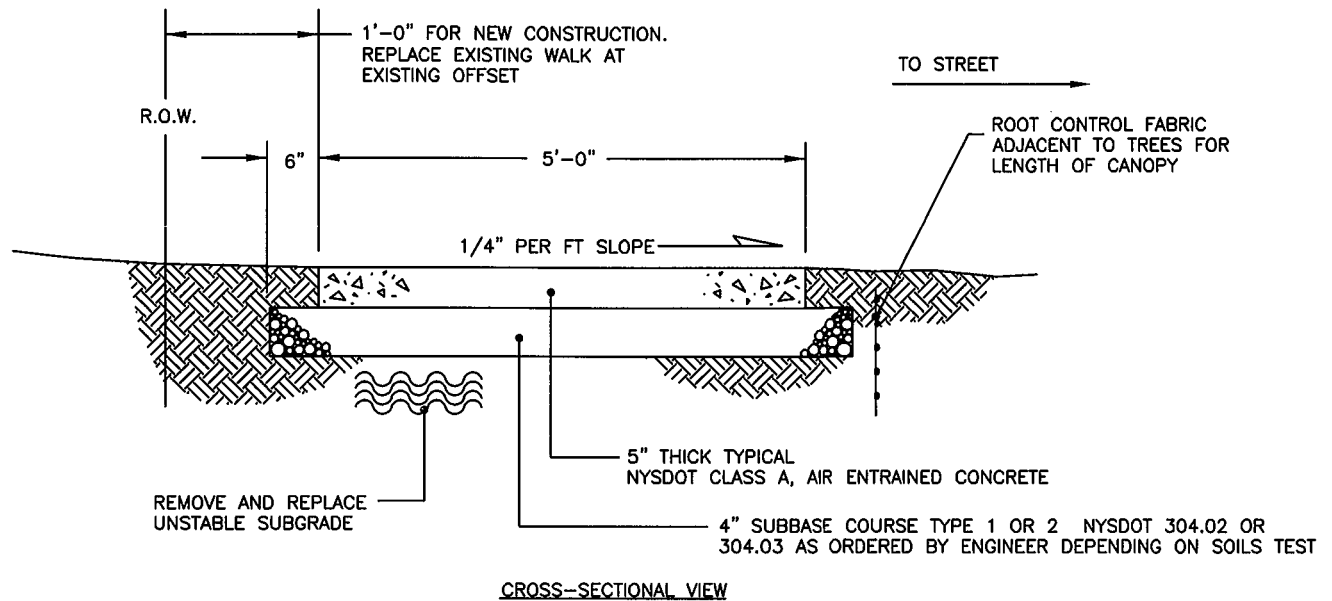

NOTES:

1. THE GRAVEL OR STONE BASE SHALL BE PLACED ON A WELL GRADED AND COMPACTED SUBGRADE. THE GRAVEL OR STONE BASE SHALL BE THOROUGHLY COMPACTED.
2. ALL EXPOSED SURFACES SHALL BE BROOMED AND EDGES FINISHED WITH A 1/4" RADIUS EDGING TOOL. THE FINISHED CONCRETE SURFACE TEMPERATURE IS ABOVE 40 DEGREES.
3. NO CONCRETE SHALL BE PLACED BEFORE APRIL 20TH, OR AFTER OCTOBER 31ST. NO CONCRETE SHALL BE PLACED UNLESS THE AMBIENT AIR SURFACE TEMPERATURE IS ABOVE 40 DEGREES.
4. ALL WORK SHALL CONFORM TO ADA REQUIREMENTS.
5. EXPANSION JOINTS SHALL BE 1/2" THICK PREMOULDED RESILIENT JOINT FILLER MEETING NYSOT 7-5-07 FULL WIDTH AND DEPTH OF CONCRETE SLAB.
6. CONTRACTION JOINT SAW CUT OR WET CUT WITH JOINT TOOL MIN. 1" DEEP.
7. CONSTRUCTION JOINTS SAW CUT AT JOINT NEAREST CONSTRUCTION LIMITS.

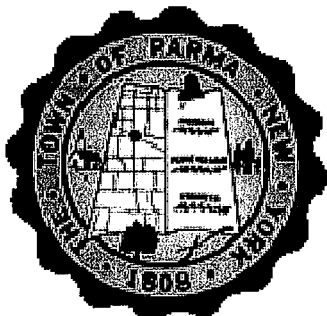

Standard Detail No. H-9
 Typical Sidewalk Detail
 Scale: N.T.S.

Town of Parma
 Development Regulations

October 2013

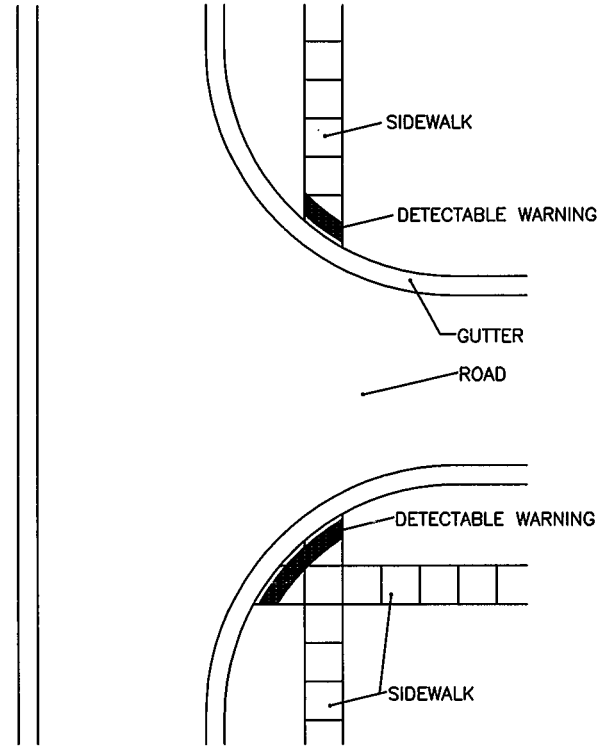
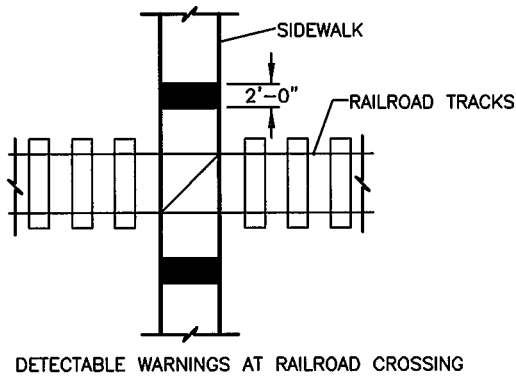
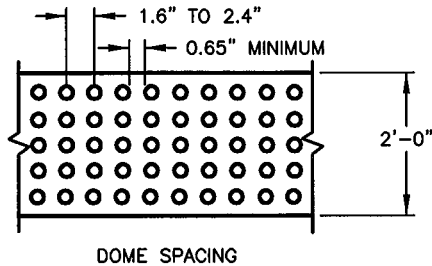
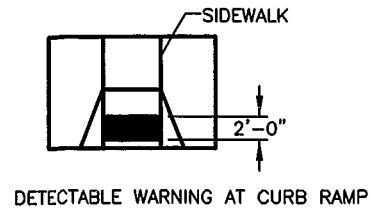
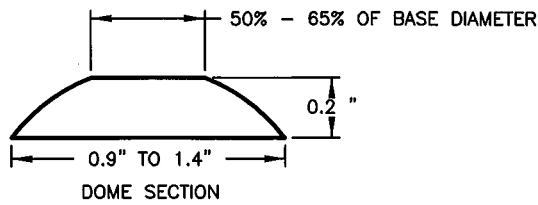

DETECTABLE WARNING AT INTERSECTIONS

GENERAL NOTES:

1. CURB RAMPS AND BLENDED TRANSITIONS: DETECTABLE WARNINGS SHALL BE LOCATED SO THAT THE EDGE OF THE WARNING FIELD NEAREST TO THE ROADWAY OR STREET SURFACE IS 6 INCHES MINIMUM AND 8 INCHES MAXIMUM FROM THE CURB LINE. THE DETECTABLE WARNING SHALL EXTEND THE FULL WIDTH OF THE CURB RAMP OR FLUSH SURFACE.
2. RAIL CROSSINGS: DETECTABLE WARNINGS SHALL BE LOCATED TO THAT THE EDGE OF THE WARNING FIELD NEAREST TO THE RAILROAD CROSSING IS 17 INCHES TO 19 INCHES FROM THE FACE OF THE GATE ARM. WHERE THERE IS NO GATE, THE EDGE OF THE WARNING FIELD NEAREST TO THE RAILROAD CROSSING SHALL BE 15 FEET FROM THE CENTERLINE OF THE NEAREST TRACK.
3. DOME ALIGNMENT: DOMES SHALL BE ALIGNED ON A SQUARE GRID IN THE PREDOMINANT DIRECTION OF TRAVEL.
4. COLOR: THE DETECTABLE WARNING FIELD SHALL BE "CHARCOAL" IN COLOR, UNLESS OTHERWISE SPECIFIED.
5. DETECTABLE WARNINGS SHALL BE STAMPED CAST IN PLACE CONCRETE.

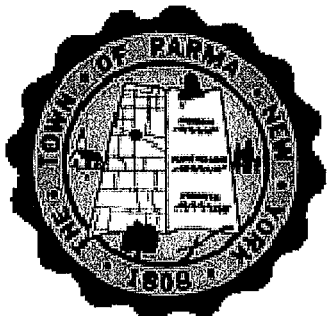

Standard Detail No. H-10
 Typical ADA Sidewalk Detectable Warnings
 Scale: N.T.S.

Town of Parma
 Development Regulations

October 2013

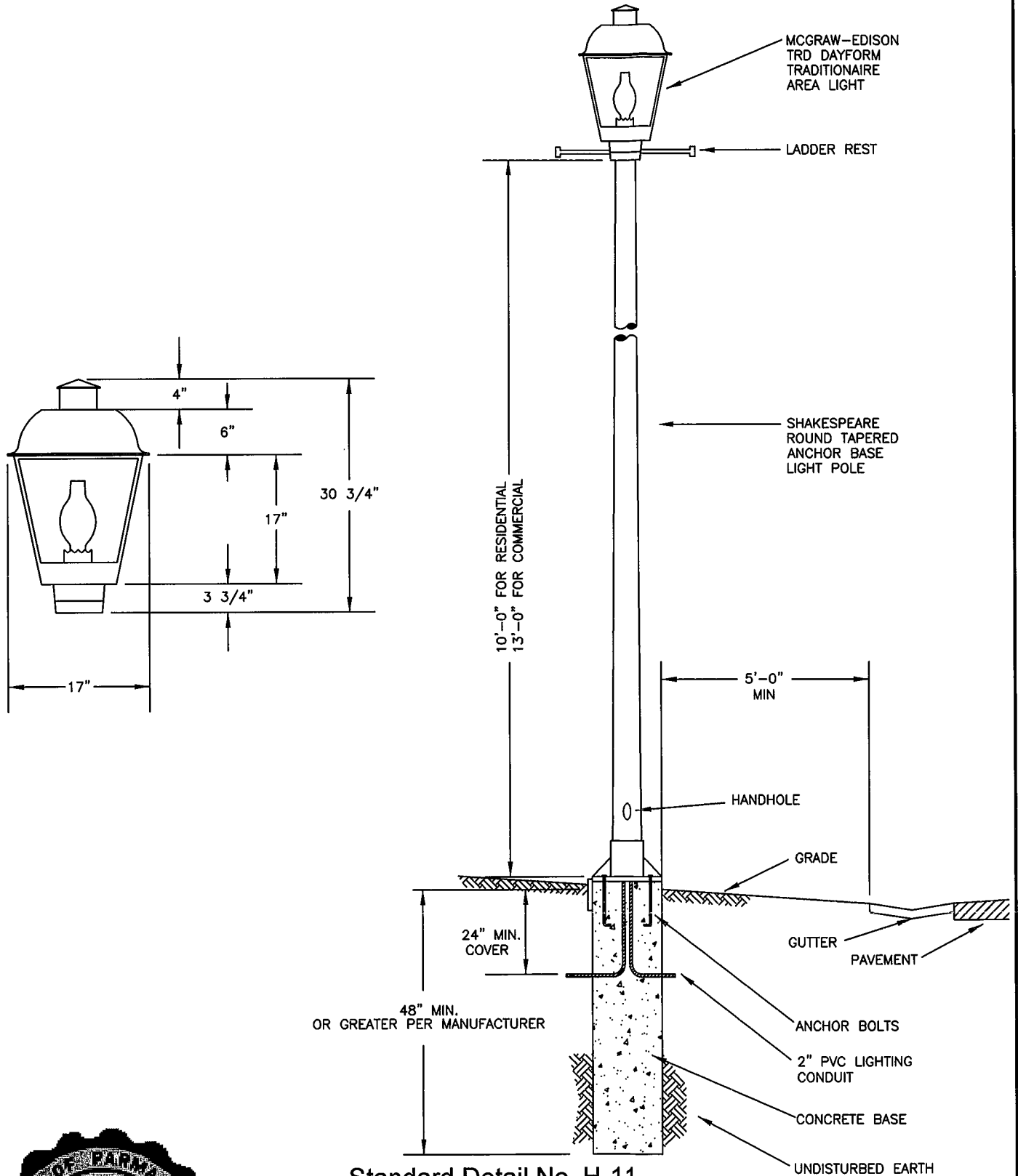

Standard Detail No. H-11
 Typical Light Pole Standard Detail
 Scale: N.T.S.

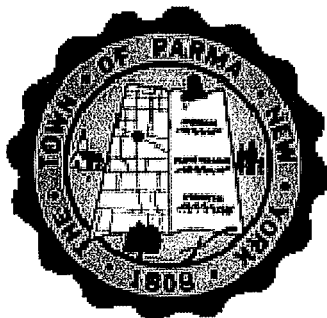

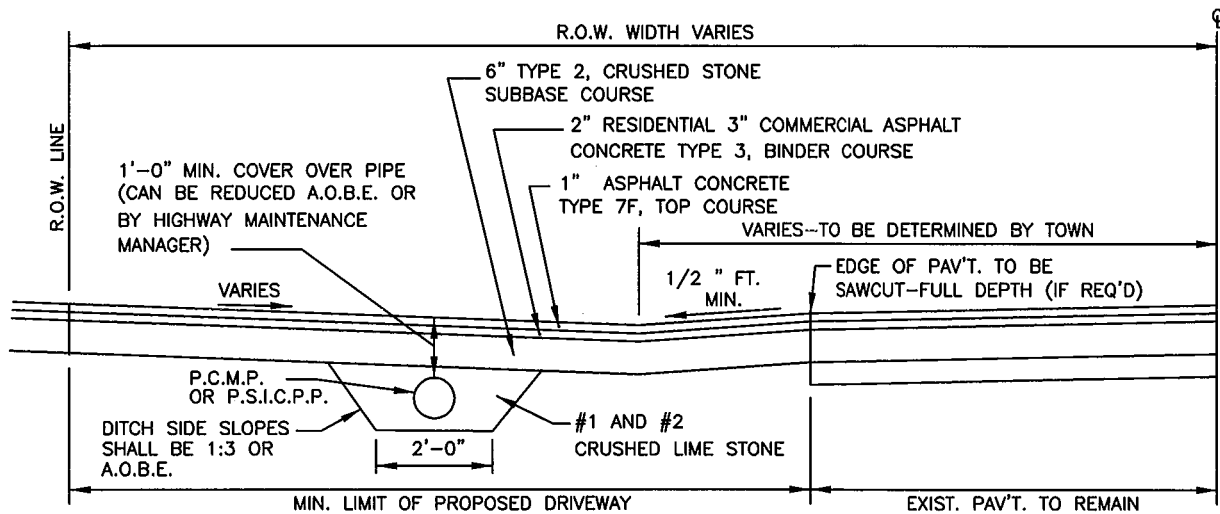
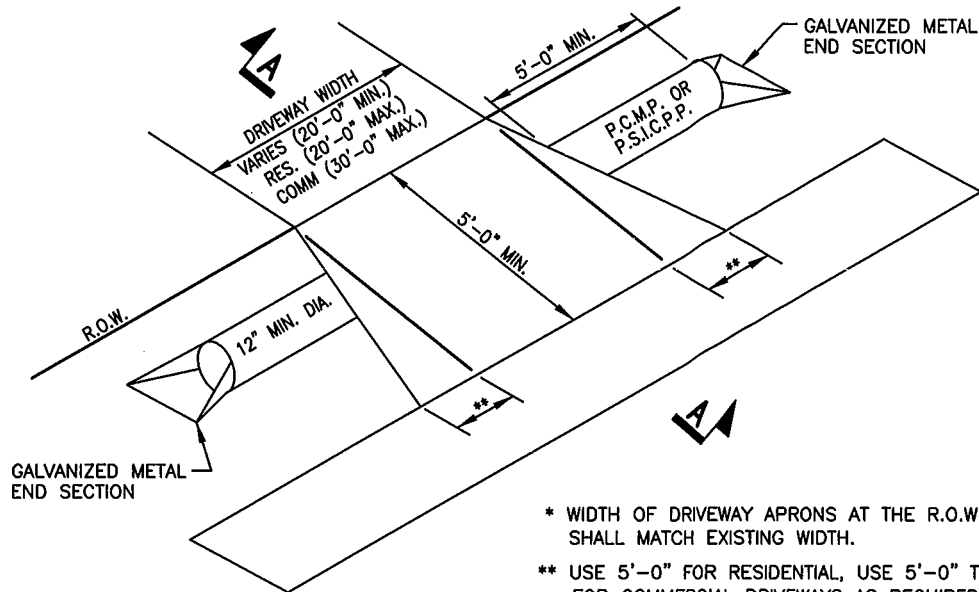

SECTION A-A

NOTES:

1. CULVERT PIPE MUST BE EITHER PERFORATED CORRUGATED METAL PIPE (PCMP), (16 GAUGE) OR SMOOTH INTERIOR CORRUGATED PERFORATED POLYETHYLENE PIPE (SICPPP). MIN. PIPE SIZE TO BE 12 INCHES OR AS DIRECTED BY TOWN.
2. THE EXISTING DRAINAGE DITCH MUST BE CLEANED AND GRADED TO DRAIN ACROSS THE ENTIRE HIGHWAY FRONTAGE.
3. THE PLACEMENT OF THE CULVERT IS DETERMINED BY THE LINE, GRADE, AND OFFSET OF THE EXISTING DITCH AND ADJACENT DRIVEWAY CULVERTS.
4. IT IS DESIRABLE THAT DRIVEWAYS TO TOWN ROADS BE PAVED TO THE RIGHT-OF-WAY LINE. THE DRIVEWAY SHALL SLOPE AWAY FROM THE OUTSIDE EDGE OF THE SHOULDER AT A MINIMUM OF 1/2 INCH PER FOOT TO THE CENTERLINE OF DRAINAGE.
5. CONCRETE DRIVEWAYS SHALL BE MIN. 5" THICK.

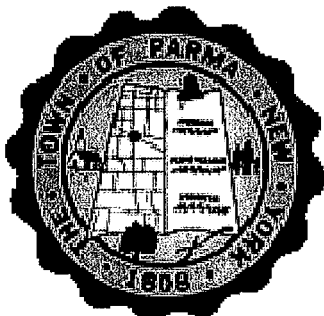

Standard Detail No. H-12
Typical Driveway with Culvert
Scale: N.T.S.

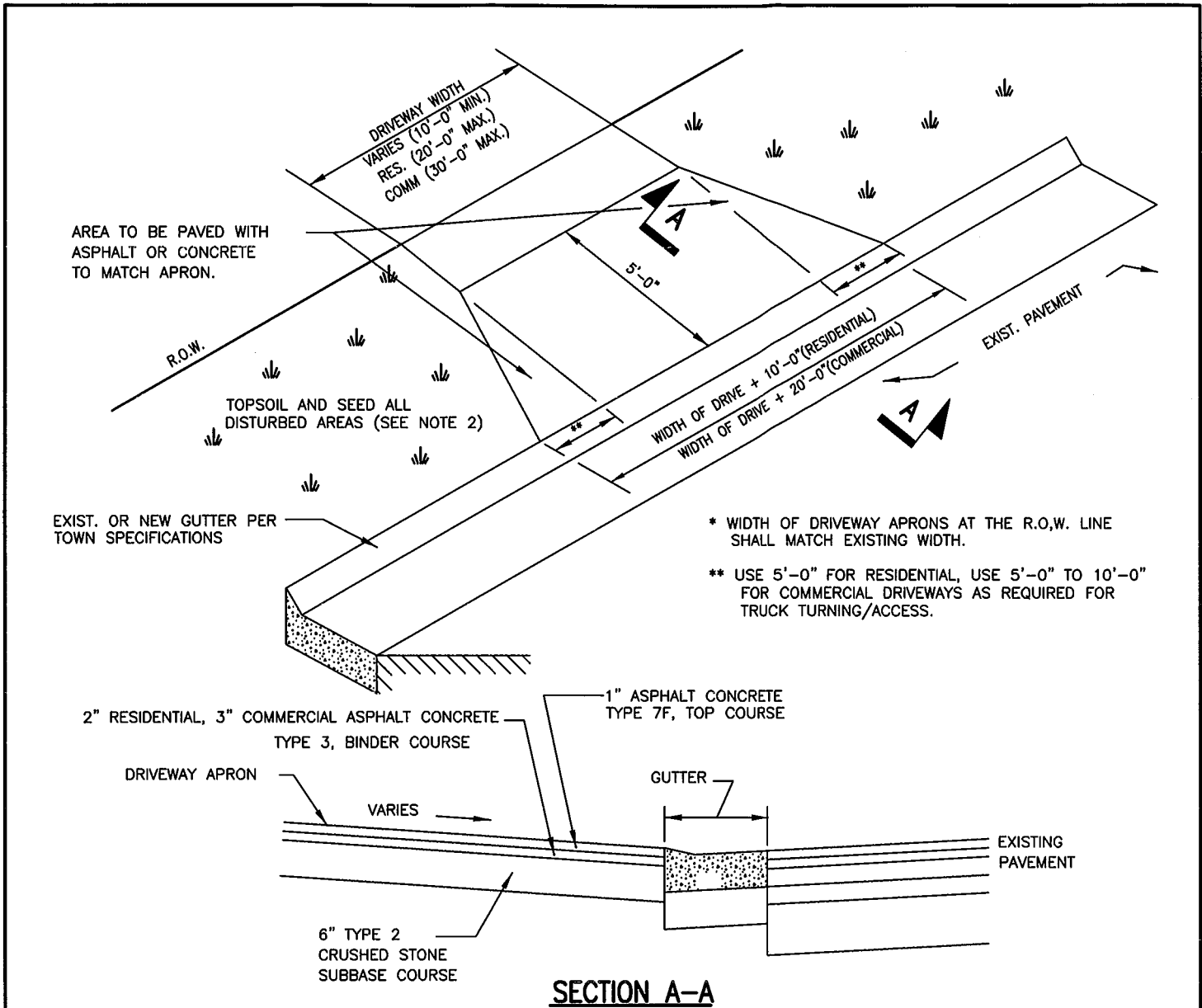

* WIDTH OF DRIVEWAY APRONS AT THE R.O.W. LINE SHALL MATCH EXISTING WIDTH.

** USE 5'-0" FOR RESIDENTIAL, USE 5'-0" TO 10'-0" FOR COMMERCIAL DRIVEWAYS AS REQUIRED FOR TRUCK TURNING/ACCESS.

SECTION A-A

NOTES:

1. ALL PAVEMENT JOINTS SHALL BE TACK COATED AND SEALED WITH BITUMINOUS SEALER.
2. TOPSOIL AND SEED ALL DISTURBED AREAS WITH TOPSOIL ITEM NO. 613.0101 AND SEED ITEM NO. 610.0203.
3. EXPANSION JOINT MATERIAL TO BE PLACED A.O.B.E.
4. IT IS DESIRABLE THAT DRIVEWAYS TO TOWN ROADS BE PAVED TO THE RIGHT-OF-WAY LINE. THE DRIVEWAY SHALL SLOPE AWAY FROM THE OUTSIDE EDGE OF THE SHOULDER AT A MINIMUM OF 1/2 INCH PER FOOT TO THE CENTERLINE OF DRAINAGE.
5. CONCRETE DRIVEWAYS SHALL BE MINIMUM 5" THICK.



Standard Detail No. H-13
 Typical Driveway with Gutter
 Scale: N.T.S.

Town of Parma
 Development Regulations

October 2013